

GUIDE TO EXTERNAL TURNING TOOLS

Section organization

- ① Organized according to turning insert shape. (Refer to the index on the next page.)

TYPE OF TOOL HOLDER indicates the first four letters of the order number, as well as cutting applications.

TITLE OF PRODUCT BY INSERT TYPE
PRODUCT SECTION

FIGURE SHOWING TOOLING APPLICATION uses illustrations and arrows to depict the possible machining applications such as external turning, copying, facing, and chamfering together with cutting edge lead angles.

GEOMETRY
CHIP BREAKER BY CUTTING APPLICATION

EXTERNAL TURNING TOOLS

DCN INSERTS TOOL HOLDERS

DOUBLE CLAMP Type

Order Number	Stock	Insert Number	Dimensions (inch)							Shim	Shim Pin	Clamp Bridge	Setting	Clamp Screw	Wrench
			H	B	LF	LH	HF	WF							
DCLNR/L-123	●●	32	.750	.750	4.500	1.000	.750	1.000	LLSON43	LLP23	DCQ211	DCS2	DCQ20T	TKY15F	
DCLNR/L-124	●●	43	.750	.750	4.500	1.250	.750	1.000	LLSON42	LLP14	DCQ211	DCS1	DCQ20T	TKY20F	
DCLNR/L-163	●●	32	1.000	1.000	6.000	1.000	1.000	1.250	LLSON21	LLP23	DCQ211	DCS2	DCQ20T	TKY15F	
DCLNR/L-164	●●	43	1.000	1.000	6.000	1.250	1.000	1.250	LLSON42	LLP14	DCQ211	DCS1	DCQ20T	TKY20F	
DCLNR/L-204	●●	43	1.250	1.250	6.000	1.250	1.250	1.500	LLSON42	LLP14	DCQ211	DCS1	DCQ20T	TKY20F	
DCLNR/L-244	●●	43	1.500	1.500	6.000	1.250	1.500	2.000	LLSON42	LLP14	DCQ211	DCS1	DCQ20T	TKY20F	

*1 Please use shim LLSCN12 with .1875 inch thick insert. When using .1875 inch thick inserts, the shim must be ordered separately.
*2 Clamp Torque (lb-in) : DCQ520T-31, DCQ621T-44

MCLN INSERTS TOOL HOLDERS

Multiple Clamp Type M Holder

Order Number	Stock	Insert Number	Dimensions (inch)							Shim	Shim Pin	Clamp Bridge	Clamp Screw
			H	B	LF	LH	HF	WF					
MCLNR/L-123	●●	32	.750	.750	4.500	1.187	.750	1.000	ICSN322	NL34	CL7	XNS36	
MCLNR/L-124B	●●	43	.750	.750	4.500	1.250	.750	1.000	ICSN333	NL46	CL20	XNS48	
MCLNR/L-163	●●	32	1.000	1.000	6.000	1.187	1.000	1.250	ICSN322	NL34	CL7	XNS36	
MCLNR/L-164C	●●	43	1.000	1.000	6.000	1.250	1.000	1.250	ICSN433	NL46	CL20	XNS48	
MCLNR/L-164D	●●	43	1.000	1.000	6.000	1.250	1.000	1.250	ICSN433	NL46	CL20	XNS48	
MCLNR/L-165C	●●	64	1.000	1.000	6.000	1.375	1.000	1.250	ICSN633	NL58	CL12	XNS510	
MCLNR/L-165D	●●	64	1.000	1.000	6.000	1.375	1.000	1.250	ICSN633	NL58	CL12	XNS510	
MCLNR/L-166C	●●	64	1.000	1.000	6.000	1.500	1.000	1.250	ICSN633	NL68	CL12	XNS510	
MCLNR/L-166D	●●	64	1.000	1.000	6.000	1.500	1.000	1.250	ICSN633	NL68	CL12	XNS510	
MCLNR/L-204D	●●	43	1.250	1.250	6.000	1.187	1.250	1.500	ICSN433	NL46	CL20	XNS48	
MCLNR/L-205D	●●	64	1.250	1.250	6.000	1.375	1.250	1.500	ICSN633	NL68	CL12	XNS510	
MCLNR/L-206D	●●	64	1.250	1.250	6.000	1.500	1.250	1.500	ICSN633	NL68	CL12	XNS510	
MCLNR/L-244D	●●	43	1.500	1.500	6.000	1.187	1.500	2.000	ICSN433	NL46	CL20	XNS48	
MCLNR/L-244E	●●	43	1.500	1.500	7.000	1.187	1.500	2.000	ICSN433	NL46	CL20	XNS48	
MCLNR/L-248D	●●	64	1.500	1.500	6.000	1.500	1.500	2.000	ICSN633	NL68	CL12	XNS510	
MCLNR/L-248E	●●	64	1.500	1.500	7.000	1.500	1.500	2.000	ICSN633	NL68	CL12	XNS510	
MCLNR/L-854D	●●	43	1.250	1.000	6.000	1.187	1.250	1.250	ICSN433	NL46	CL20	XNS48	
MCLNR/L-856D	●●	64	1.250	1.000	6.000	1.500	1.250	1.250	ICSN633	NL68	CL12	XNS510	

*1 (Opt.) See page M029 for different radius.
*2 For inserts without hole, remove shim pin and add below.
*3 Clamp Torque (lb-in) : XNS36-30, XNS48-45, XNS510-70

Shim Screw	Chipbreaker
S46	CB04

C006 ● Inventory maintained.

DCLN type inserts > A09F-A102
CBN & PCD inserts > B022, B023, B051
CUTTING CONDITIONS > A074

MCLN type inserts > A09F-A102
CBN & PCD inserts > B022, B023, B051
CUTTING CONDITIONS > A074

SPARE PARTS > M001
TECHNICAL DATA > M001

LEGEND FOR STOCK STATUS MARK is shown on the left hand page of each double-page spread.

REFERENCE PAGE FOR APPLICABLE INSERTS indicates reference pages giving details of inserts that are applicable to the product.

PAGE REFERENCE
- SPARE PARTS
- TECHNICAL DATA
indicates reference pages, including the above, on the right hand page of each double-page spread.

PRODUCT STANDARDS indicates order numbers, stock status (per right/left hand), applicable inserts, dimensions, and spare parts.

●To Order : Please specify order number and hand of tool (right/left).

TURNING

EXTERNAL TURNING TOOLS

CLASSIFICATION..... C002

IDENTIFICATION..... C004

STANDARD HOLDERS

CN⁰⁰ INSERTS TOOL HOLDERS..... C006

DN⁰⁰ INSERTS TOOL HOLDERS..... C010

RN⁰⁰ INSERTS TOOL HOLDERS..... C013

SN⁰⁰ INSERTS TOOL HOLDERS..... C014

TN⁰⁰ INSERTS TOOL HOLDERS..... C018

VN⁰⁰ INSERTS TOOL HOLDERS..... C024

WN⁰⁰ INSERTS TOOL HOLDERS..... C027

VB⁰⁰ INSERTS TOOL HOLDERS..... C028

CC⁰⁰ INSERTS TOOL HOLDERS..... C030

DC⁰⁰ INSERTS TOOL HOLDERS..... C031

RC⁰⁰ INSERTS TOOL HOLDERS..... C033

SC⁰⁰ INSERTS TOOL HOLDERS..... C034

TC⁰⁰ INSERTS TOOL HOLDERS..... C035

VC⁰⁰ INSERTS TOOL HOLDERS..... C036

WC⁰⁰ INSERTS TOOL HOLDERS..... C037

XC⁰⁰ INSERTS TOOL HOLDERS..... C038

RP⁰⁰ INSERTS TOOL HOLDERS..... C040

DE⁰⁰ INSERTS TOOL HOLDERS..... C041

TE⁰⁰ INSERTS TOOL HOLDERS..... C042

VD⁰⁰ INSERTS TOOL HOLDERS..... C043







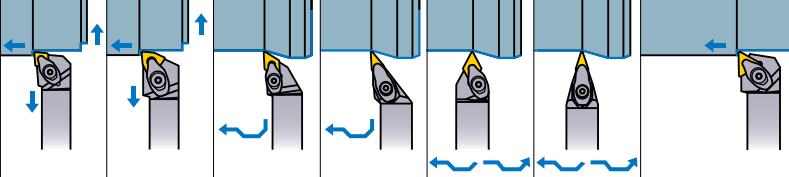

RG⁰⁰ INSERTS TOOL HOLDERS..... C044

*Arranged by Alphabetical order

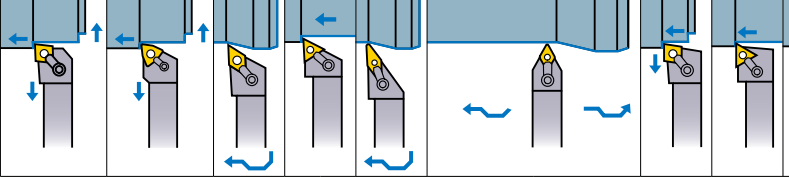
C006	DCLN	C010	MDJN	C032	SDXC
C008	DCRN	C011	MDPN	C033	SRDC
C010	DDJN	C013	MRGN	C040	SRDP
C011	DDPN	C016	MSDN	C033	SRGC
C012	DDQN	C017	MSKN	C044	SRSG
C013	DRGN	C014	MSRN	C034	SSBC
C016	DSDN	C015	MSSN	C034	SSSC
C017	DSKN	C020	MTAN	C035	STFC
C014	DSRN	C021	MTCN	C042	STFE
C015	DSSN	C021	MTEN	C035	STGC
C022	DTCN	C023	MTFN	C042	STGE
C022	DTFN	C019	MTGN	C029	SVHB
C018	DTGN	C018	MTJN	C028	SVJB
C024	DVJN	C020	MTRN	C036	SVJC
C025	DVPN	C024	MVJN	C043	SVJD
C025	DVVN	C026	MVLN	C036	SVPC
C027	DWLN	C027	MWLN	C043	SVPD
C009	MCFN	C030	SCLC	C028	SVVB
C008	MCGN	C031	SDJC	C037	SWLC
C007	MCLN	C041	SDJE	C038	SXZC
C009	MCRN	C031	SDNC		

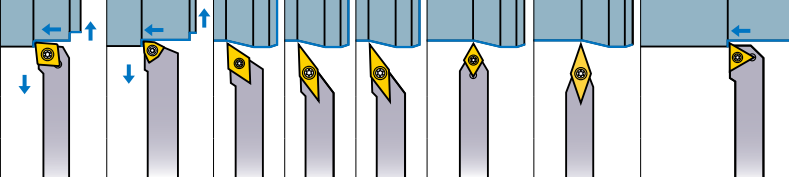
CLASSIFICATION

EXTERNAL TURNING TOOLS

Tool Holder	Features	External Turning Facing	External Turning Copying		External Turning						
		KAPR= 95°	KAPR= 93°	KAPR= 62° 30' 72° 30'		KAPR= 90° – 91°					
DOUBLE CLAMP Holder  <ul style="list-style-type: none"> ● New double clamp type. ● Holds inserts securely. ● Excellent cutting edge tolerance. ● Economical negative insert. ● Recommended with CBN grade insert 		DCLN ↻ C006	DWLN ↻ C027	DDJN ↻ C010	DVJN ↻ C024	DDPN ↻ C011	DVVN ↻ C025	DTGN ↻ C018			
M Holder  <ul style="list-style-type: none"> ● Negative rake clamp and locking pin toolholders. ● Insert is securely held by a shim pin and clamp bridge. ● Index operation is easy to perform. ● (Opt.) Single clamp available as clamp on or pin lock holder. 		MCLN ↻ C007	MWLN ↻ C027	MDJN ↻ C010	MTJN ↻ C018	MVJN ↻ C024	MDPN ↻ C011	MCGN ↻ C008	MTGN ↻ C019	MTAN ↻ C020	
SP Holder  <ul style="list-style-type: none"> ● Small shank toolholder system using a 5°, 7° and 11° positive inserts retained by screw-on system. 		SCLC ↻ C030	SWLC ↻ C037	SDJC ↻ C031	SVJC ↻ C036	SVJB ↻ C028	SDNC ↻ C031	SVVB ↻ C028	STGC ↻ C035		
PROFILE Holder  <ul style="list-style-type: none"> ● 25° rhombic insert for profiling and face relief. ● Machine 300° of a sphere. ● Machine face relief to 60° angle. ● The cycle time can be reduced due to only one holder. 											
AL Holder  <ul style="list-style-type: none"> ● Shank size .625 square thru 1.000 square with screw-on method. ● Suitable for finishing aluminum or non-ferrous metals and for chatter control on small diameters. 				SDJE ↻ C041	SVJD ↻ C043				STGE ↻ C042		
SR Holder  <ul style="list-style-type: none"> ● High positive cutting rake angle (24°) round insert retained by screw-on system. ● Rough machining of super alloys, stainless and tough-to-cut materials. 											

	External Turning	External Turning, Chamfering		External Turning, Facing, Chamfering	Facing		Facing Copying	External Turning, Copying	Selection Standard						
	KAPR= 75°	KAPR=60°	KAPR= 45°	KAPR= 45°	PSIR= 15°	PSIR= 0°--1°	PSIR= 5°--	Special Design	Economical	Low Cutting Resistance (Sharpness)	Clamp Rigidity	Operation Efficiency	Specialized		
											○	○	○		
	DCRN ⊕ C008	DSRN ⊕ C014	DSDN ⊕ C016	DSSN ⊕ C015	DSKN ⊕ C017	DTCN ⊕ C022	DTFN ⊕ C022	DVPN ⊕ C025	DDQN ⊕ C012	DRGN ⊕ C013					
													○	○	○
	MCRN ⊕ C009	MSRN ⊕ C014	MTRN ⊕ C020	MTEN ⊕ C021	MSDN ⊕ C016	MSSN ⊕ C015	MSKN ⊕ C017	MCFN ⊕ C009	MTCN ⊕ C021	MTFN ⊕ C023	MVLN ⊕ C026	MRGN ⊕ C013			
													○		
	SSBC ⊕ C034				SSSC ⊕ C034			STFC ⊕ C035	SVHB ⊕ C029	SVPC ⊕ C036	SRDC ⊕ C033	SRDPR/LN ⊕ C040			
													○		○
								SXZC ⊕ C038							
													○		○
						STFE ⊕ C042		SVPD ⊕ C043							
													○		○
								SRSGR/L ⊕ C044	SRSGR/L ⊕ C044	SRSGR/L ⊕ C044	SRSGR/L ⊕ C044	SRSGR/L ⊕ C044			

(Note) ○ : 1st recommendation. ○ : 2nd recommendation.

IDENTIFICATION

DOUBLE CLAMP Holder, M Holder, SP Holder, PROFILE Holder, AL Holder, SR Holder

EXTERNAL TURNING TOOLS

D Double Clamp Type	C 80° Rhombic	D 55° Rhombic	R Round	S Square	A 90°	B 75°	D 45°	E 60°	F 90°	G 90°
M Multiple Clamp Type	T Triangular	V 35° Rhombic	W Trigon	X Special Design	J 93°	K 75°	L 95°	N 62°30'	Q 15°	R 75°
S Screw Clamp Type	① Method of Holding	② Insert Shape			③ Tool Style					

M **C** **L** **N** **R** - **16** **5** **D**

① ② ③ ④ ⑤ ⑥ ⑦ ⑧

④ Insert Relief Angle	
B 5°	C 7°
D 15°	E 20°
N 0°	P 11°

⑥ Tool Size [Height (H) and Width (B)] (inch)

	06	08	10	12	16	20	24	85
H	.375	.500	.625	.750	1.000	1.250	1.500	1.250
B	.375	.500	.625	.750	1.000	1.250	1.500	1.000

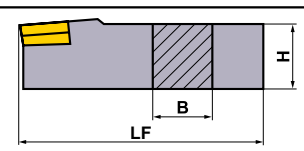

In case of B=H, the number will represent the number of sixteenths of B and H.
In case of B≠H, the first digit represents the number of eighths of B, and the second digit represents the number of quarters of H.

⑤ Hand of Tool		
R 	L 	N

⑦ Insert Size									
Inscribed Circle of Insert (inch)	.188	.219	.250	.313	.375	.500	.625	.750	1.000
	1.5	1.8	2	2.5	3	4	5	6	8
			2	2.5	3	4	5	6	8
			2	2.5	3	4	5	6	
80°					3	4	5	6	8
55°					3	4	5	6	8
35°			2		3				

⑧ Tool Length (LF) (inch)

B	C	D	E
4.500	5.000	6.000	7.000

METHOD OF HOLDING

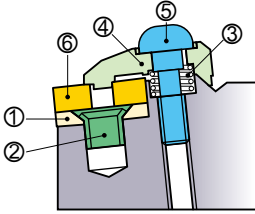
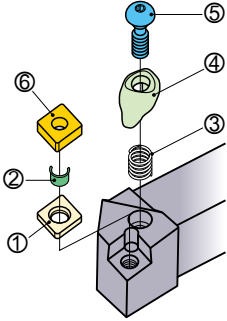
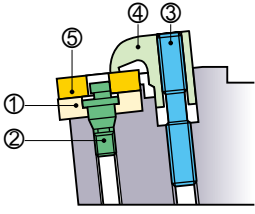
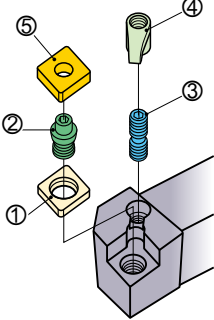
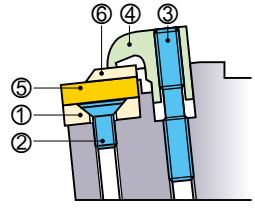
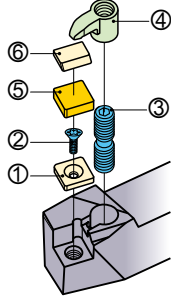
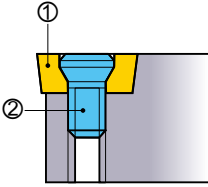
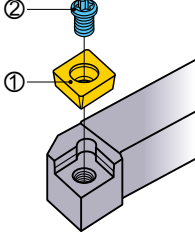
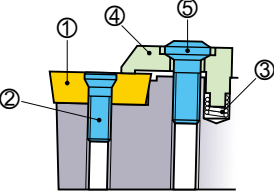
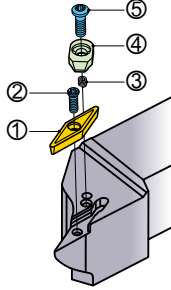
Type	Structure	
Double Clamp (DOUBLE CLAMP) Holder		<ul style="list-style-type: none"> ① Shim ② Shim Pin ③ Spring ④ Clamp Bridge ⑤ Clamp Screw ⑥ Insert 
Multiple Clamp For insert with hole (M Holder)		<ul style="list-style-type: none"> ① Shim ② Shim Pin ③ Clamp Screw ④ Clamp Bridge ⑤ Insert 
Multiple Clamp For insert without hole (Opt.) (M Holder)		<ul style="list-style-type: none"> ① Shim ② Shim Screw ③ Clamp Screw ④ Clamp Bridge ⑤ Insert ⑥ Chipbreaker 
Screw Clamp (SP Holder) (AL Holder) (SR Holder)		<ul style="list-style-type: none"> ① Insert ② Insert Screw 
Double Clamp with Screw and Clamp Bridge (PROFILE Holder)		<ul style="list-style-type: none"> ① Insert ② Insert Screw ③ Spring ④ Clamp Bridge ⑤ Clamp Screw 

CN TOOL HOLDERS

DCLN

External turning **DOUBLE CLAMP Type**
Facing

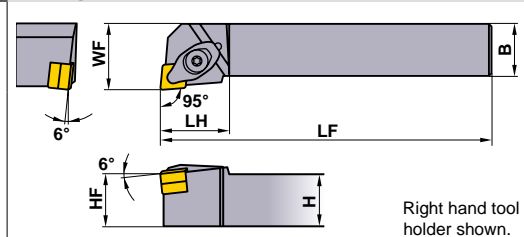
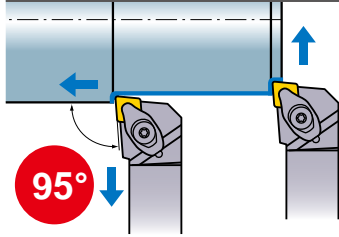

Finish	Light	Medium	Medium
FH (4)	LP (4)	MP (4)	MK (4)
Medium Standard	Medium to Rough	Stainless	CBN
 (3,4)	RP (4)	MS (4)	 (4)

Right hand tool holder shown.

EXTERNAL TURNING TOOLS

Order Number	Stock		Insert Number	Dimensions (inch)											
	R	L		H	B	LF	LH	HF	WF	Shim	Shim Pin	Clamp Bridge	Spring	Clamp Screw	Wrench
DCLNR/L-123	●	●	32	.750	.750	4.500	1.000	.750	1.000	LLSCN33*1 (LLSCN32)	LLP23	DCK2211	DCS2	DC0520T	TKY15F
DCLNR/L-124	●	●	43	.750	.750	4.500	1.250	.750	1.000	LLSCN42	LLP14	DCK2613	DCS1	DC0621T	TKY20F
DCLNR/L-163	●	●	32	1.000	1.000	6.000	1.000	1.000	1.250	LLSCN33*1 (LLSCN32)	LLP23	DCK2211	DCS2	DC0520T	TKY15F
DCLNR/L-164	●	●	43	1.000	1.000	6.000	1.250	1.000	1.250	LLSCN42	LLP14	DCK2613	DCS1	DC0621T	TKY20F
DCLNR/L-204	●	●	43	1.250	1.250	6.000	1.250	1.250	1.500	LLSCN42	LLP14	DCK2613	DCS1	DC0621T	TKY20F
DCLNR/L-244	●	●	43	1.500	1.500	6.000	1.250	1.500	2.000	LLSCN42	LLP14	DCK2613	DCS1	DC0621T	TKY20F

*1 Please use shim no.LLSCN32 with .187inch thick insert. When using .187inch thick inserts, the shim must be ordered separately.

*2 Clamp Torque (lbf-in) : DC0520T=31, DC0621T=44

(Note) Insert photo is an example. Letters show chip breaker style, figures show inscribed circle.

DCLN type inserts	> A096-A102
CBN & PCD inserts	> B022, B023, B051
CUTTING CONDITIONS	> A074

MCLN

External turning Facing

Multiple Clamp Type
M Holder

Finish



(4)

Light



(4)

Medium



(4,5)

Medium



(4,5,6)

Medium



(3,4,5,6)

Medium to Rough



(4)

Stainless



(3,4,5,6)





CBN

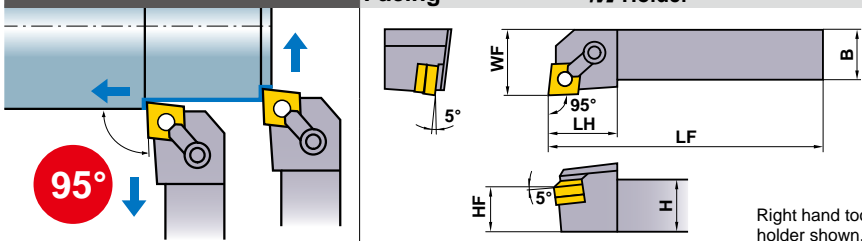

(4)



Right hand tool holder shown.

Order Number	Stock		Insert Number	Dimensions (inch)						    ^{*3}			
	R	L		H	B	LF	LH	HF	WF	Shim	Shim Pin	Clamp Bridge	Clamp Screw
MCLNR/L-123	●	●	32	.750	.750	4.500	1.187	.750	1.000	ICSN322	NL34	CL7	XNS36
MCLNR/L-124B	●	●	43 ^{*2}	.750	.750	4.500	1.250	.750	1.000	ICSN433 ^{*1}	NL46	CL20	XNS48
MCLNR/L-163	●	●	32	1.000	1.000	6.000	1.187	1.000	1.250	ICSN322	NL34	CL7	XNS36
MCLNR/L-164C	●	●	43 ^{*2}	1.000	1.000	5.000	1.250	1.000	1.250	ICSN433 ^{*1}	NL46	CL20	XNS48
MCLNR/L-164D	●	●	43 ^{*2}	1.000	1.000	6.000	1.250	1.000	1.250	ICSN433 ^{*1}	NL46	CL20	XNS48
MCLNR/L-165C	●	●	54	1.000	1.000	5.000	1.375	1.000	1.250	ICSN533	NL58	CL12	XNS510
MCLNR/L-165D	●	●	54	1.000	1.000	6.000	1.375	1.000	1.250	ICSN533	NL58	CL12	XNS510
MCLNR/L-166C	●	●	64	1.000	1.000	5.000	1.500	1.000	1.250	ICSN633	NL68	CL12	XNS510
MCLNR/L-166D	●	●	64	1.000	1.000	6.000	1.500	1.000	1.250	ICSN633	NL68	CL12	XNS510
MCLNR/L-204D	●	●	43 ^{*2}	1.250	1.250	6.000	1.187	1.250	1.500	ICSN433 ^{*1}	NL46	CL20	XNS48
MCLNR/L-205D	●	●	54	1.250	1.250	6.000	1.375	1.250	1.500	ICSN533	NL58	CL12	XNS510
MCLNR/L-206D	●	●	64	1.250	1.250	6.000	1.500	1.250	1.500	ICSN633	NL68	CL12	XNS510
MCLNR/L-244D	●	●	43 ^{*2}	1.500	1.500	6.000	1.187	1.500	2.000	ICSN433 ^{*1}	NL46	CL20	XNS48
MCLNR/L-244E	●	●	43 ^{*2}	1.500	1.500	7.000	1.187	1.500	2.000	ICSN433 ^{*1}	NL46	CL20	XNS48
MCLNR/L-246D	●	●	64	1.500	1.500	6.000	1.500	1.500	2.000	ICSN633	NL68	CL12	XNS510
MCLNR/L-246E	●	●	64	1.500	1.500	7.000	1.500	1.500	2.000	ICSN633	NL68	CL12	XNS510
MCLNR/L-854D	●	●	43 ^{*2}	1.250	1.000	6.000	1.187	1.250	1.250	ICSN433 ^{*1}	NL46	CL20	XNS48
MCLNR/L-856D	●	●	64	1.250	1.000	6.000	1.500	1.250	1.250	ICSN633	NL68	CL12	XNS510

*1 (Opt.) See page M009 for different radius. *2 For inserts without hole, remove shim pin and add below.
 *3 Clamp Torque (lbf-in) : XNS36=30, XNS48=45, XNS510=70

Shim Screw	Chipbreaker
S46	CBC4

CN INSERTS TOOL HOLDERS

EXTERNAL TURNING TOOLS

MCGN External turning **Multiple Clamp Type M Holder**

Finish	Light	Medium	Medium
FH (4)	LP (4)	MP (4,5)	MH (4,5,6)
Medium	Medium to Rough	Stainless	CBN
Standard (4,5,6)	RP (4,5,6)	MM (4,5,6)	 (4)

Order Number	Stock		Insert Number	Dimensions (inch)										
	R	L		H	B	LF	LH	HF	WF	Shim	Shim Pin	Clamp Bridge	Clamp Screw	
MCGNR/L-124	<input type="checkbox"/>	<input type="checkbox"/>	CNMA CNMG CNMM CNGG	43 ^{*2}	.750	.750	4.500	1.250	.750	1.000	ICSN433 ^{*1}	NL46	CL20	XNS48
MCGNR/L-164C	<input type="checkbox"/>	<input type="checkbox"/>		43 ^{*2}	1.000	1.000	5.000	1.250	1.000	1.250	ICSN433 ^{*1}	NL46	CL20	XNS48
MCGNR/L-164D	<input checked="" type="checkbox"/>	<input checked="" type="checkbox"/>		43 ^{*2}	1.000	1.000	6.000	1.250	1.000	1.250	ICSN433 ^{*1}	NL46	CL20	XNS48
MCGNR/L-165D	<input checked="" type="checkbox"/>	<input checked="" type="checkbox"/>		54	1.000	1.000	6.000	1.313	1.000	1.250	ICSN533	NL58	CL12	XNS510
MCGNR/L-166D	<input type="checkbox"/>	<input type="checkbox"/>		64	1.000	1.000	6.000	1.625	1.000	1.250	ICSN633	NL68	CL9	XNS510

*1 (Opt.) See page M009 for different radius.

*3 Clamp Torque (lbf-in) : XNS48=45, XNS510=70

*2 For inserts without hole, remove shim pin and add below.

Shim Screw	Chipbreaker
S46	CBC4

DCRN External turning **DOUBLE CLAMP Type**

Finish	Light	Medium	Medium
FH (4)	LP (4)	MP (4)	MH (4)
Medium	Medium to Rough	Stainless	
Standard (4)	RP (4)	MM (4)	

Order Number	Stock		Insert Number	Dimensions (inch)												
	R	L		H	B	LF	LH	HF	WF	Shim	Shim Pin	Clamp Bridge	Spring	Clamp Screw	Wrench	
DCRNR/L-124	<input checked="" type="checkbox"/>	<input checked="" type="checkbox"/>	CNMA CNMG CNMM CNGG	43	.750	.750	4.500	1.250	.750	.888	LLSCN42	LLP14	DCK2613	DCS1	DC0621T	TKY20F
DCRNR/L-164	<input checked="" type="checkbox"/>	<input checked="" type="checkbox"/>		43	1.000	1.000	6.000	1.250	1.000	1.128	LLSCN42	LLP14	DCK2613	DCS1	DC0621T	TKY20F

* Clamp Torque (lbf-in) : DC0621T=44

● : Inventory maintained.

□ : Non stock, produced to order only.

- MCGN type inserts > A096-A102
- DCRN type inserts > A096-A102
- CBN & PCD inserts > B022, B023, B051
- CUTTING CONDITIONS > A074

MCRN

75°

Multiple Clamp Type

External turning
M Holder

Right hand tool holder shown.

Finish	Light	Medium	Medium
FH	LP	MP	MK
(4)	(4)	(4,5)	(4,5,6)
Medium	Medium to Rough	Stainless	
Standard	RP	MS	
(4,5,6)	(4)	(4,5)	

Order Number	Stock		Insert Number	Dimensions (inch)										
	R	L		H	B	LF	LH	HF	WF	Shim	Shim Pin	Clamp Bridge	Clamp Screw	
MCRNR/L-124B	●	□	CNMA CNMG CNMM CNGG	43 ^{*2}	.750	.750	4.500	1.250	.750	.750	ICSN433 ^{*1}	NL46	CL20	XNS48
MCRNR/L-164C	●	●		43 ^{*2}	1.000	1.000	5.000	1.250	1.000	1.250	ICSN433 ^{*1}	NL46	CL20	XNS48
MCRNR/L-164D	●	●		43 ^{*2}	1.000	1.000	6.000	1.250	1.000	1.250	ICSN433 ^{*1}	NL46	CL20	XNS48
MCRNR/L-165D	●	□		54	1.000	1.000	6.000	1.343	1.000	1.250	ICSN533	NL58	CL9	XNS510
MCRNR/L-166D	□	□		64	1.000	1.000	6.000	1.343	1.000	1.250	ICSN633	NL68	CL12	XNS510

*1 (Opt.) See page M009 for different radius.

*2 For inserts without hole, remove shim pin and add below.

*3 Clamp Torque (lbf-in) : XNS48=45, XNS510=70

Shim Screw	Chipbreaker
S46	CBC4

MCFN

90°

Multiple Clamp Type

Facing
M Holder

Right hand tool holder shown.

Finish	Light	Medium	Medium
FH	LP	MP	MK
(4)	(4)	(4,5)	(4,5,6)
Medium	Medium to Rough	Stainless	CBN
Standard	RP	MS	
(4,5,6)	(4)	(4,5)	(4)

Order Number	Stock		Insert Number	Dimensions (inch)										
	R	L		H	B	LF	LH	HF	WF	Shim	Shim Pin	Clamp Bridge	Clamp Screw	
MCFNR/L-124	□	□	CNMA CNMG CNMM CNGG	43 ^{*2}	.750	.750	4.500	1.250	.750	1.000	ICSN433 ^{*1}	NL46	CL20	XNS48
MCFNR/L-164C	●	●		43 ^{*2}	1.000	1.000	5.000	1.250	1.000	1.250	ICSN433 ^{*1}	NL46	CL20	XNS48
MCFNR/L-164D	□	□		43 ^{*2}	1.000	1.000	6.000	1.250	1.000	1.250	ICSN433 ^{*1}	NL46	CL20	XNS48
MCFNR/L-165D	●	●		54	1.000	1.000	6.000	1.380	1.000	1.250	ICSN533	NL58	CL12	XNS510
MCFNR/L-166D	□	□		64	1.000	1.000	6.000	1.500	1.000	1.250	ICSN633	NL68	CL9	XNS510

*1 (Opt.) See page M009 for different radius.

*2 For inserts without hole, remove shim pin and add below.

*3 Clamp Torque (lbf-in) : XNS48=45, XNS510=70

Shim Screw	Chipbreaker
S46	CBC4

MCRN type inserts > A096-A102
MCFN type inserts > A096-A102
CBN & PCD inserts > B022, B023, B051

CUTTING CONDITIONS > A074
SPARE PARTS > M001
TECHNICAL DATA > N001

DN TOOL HOLDERS

EXTERNAL TURNING TOOLS

DDJN

External turning Copying *DOUBLE CLAMP Type*

Right hand tool holder shown.

Finish	Light	Medium	Medium
FH (4)	LP (4)	MP (4)	MK (4)
Medium to Rough	Stainless	G Class	CBN
RP (4)	MS (4)	MJ (4)	 (4)

Order Number	Stock		Insert Number	Dimensions (inch)						Shim Shim Pin Clamp Bridge Spring Clamp Screw *2 Wrench						
	R	L		H	B	LF	LH	HF	WF	Shim	Shim Pin	Clamp Bridge	Spring	Clamp Screw	Wrench	
DDJNR/L-123	●	●	DNMA DNMG DNMM DNGA DNGG DNGM DNMX	33	.750	.750	4.500	1.188	.750	1.000	LLSDN32	LLP23	DCK2211	DCS2	DC0520T	TKY15F
DDJNR/L-124	●	●		43	.750	.750	4.500	1.375	.750	1.000	LLSDN43 (LLSDN42)*1	LLP24 (LLP14)*1	DCK2613	DCS1	DC0621T	TKY20F
DDJNR/L-163	●	●		33	1.000	1.000	6.000	1.188	1.000	1.250	LLSDN32	LLP23	DCK2211	DCS2	DC0520T	TKY15F
DDJNR/L-164	●	●		43	1.000	1.000	6.000	1.375	1.000	1.250	LLSDN43 (LLSDN42)*1	LLP24 (LLP14)*1	DCK2613	DCS1	DC0621T	TKY20F
DDJNR/L-204	●	●		43	1.250	1.250	6.000	1.375	1.250	1.500	LLSDN43 (LLSDN42)*1	LLP24 (LLP14)*1	DCK2613	DCS1	DC0621T	TKY20F
DDJNR/L-244	●	●		43	1.500	1.500	6.000	1.500	1.500	2.000	LLSDN43 (LLSDN42)*1	LLP24 (LLP14)*1	DCK2613	DCS1	DC0621T	TKY20F

*1 Please use shim no.LLSDN42 and shim pin LLP14 with .25inch thick insert. When using .25inch thick inserts, the shim and shim pin must be ordered separately.
 *2 Clamp Torque (lbf-in) : DC0520T=31, DC0621T=44

MDJN

External turning Copying *Multiple Clamp Type M Holder*

Right hand tool holder shown.

Finish	Light	Medium	Medium
FH (4)	LP (4)	MP (4)	MK (4)
Medium to Rough	Stainless	G Class	CBN
RP (4)	MS (4)	MJ (4)	 (4)

Order Number	Stock		Insert Number	Dimensions (inch)						Shim Shim Pin Clamp Bridge Clamp Screw *2				
	R	L		H	B	LF	LH	HF	WF	Shim	Shim Pin	Clamp Bridge	Clamp Screw	
MDJNR/L -123	●	●	DNMA DNMG DNMM DNGA DNGG DNGM DNMX	33	.750	.750	4.500	1.250	.750	1.000	IDSN322	NL33L	CL7	XNS36
MDJNR/L -124B	●	●		43	.750	.750	4.500	1.250	.750	1.000	IDSN433	NL46	CL7	XNS36
MDJNR/L -163	●	●		33	1.000	1.000	5.000	1.250	1.000	1.250	IDSN322	NL33L	CL7	XNS36
MDJNR/L -164C	●	●		43	1.000	1.000	5.000	1.250	1.000	1.250	IDSN433	NL46	CL20	XNS48
MDJNR/L -164D	●	●		43	1.000	1.000	6.000	1.250	1.000	1.250	IDSN433	NL46	CL20	XNS48
MDJNR/L -165D	●	●		54*1	1.000	1.000	6.000	1.469	1.000	1.250	IDSN533*1	NL58	CL12	XNS510
MDJNR/L -204D	●	●		43	1.250	1.250	6.000	1.250	1.250	1.500	IDSN433	NL46	CL20	XNS48
MDJNR/L -205D	●	●		54*1	1.250	1.250	6.000	1.469	1.250	1.500	IDSN533*1	NL58	CL12	XNS510
MDJNR/L -244D	●	●		43	1.500	1.500	6.000	1.250	1.500	2.000	IDSN433	NL46	CL20	XNS48

*1 (Opt.) See page M009 for different thickness.
 *2 Clamp Torque (lbf-in) : XNS36=30, XNS48=45, XNS510=70
 (Note) Insert photo is an example. Letters show chip breaker style, figures show inscribed circle.

DDPN		External turning Copying		DOUBLE CLAMP Type					Finish	Light	Medium	Medium		
								FH (4)	LP (4)	MP (4)	MK (4)			
				Medium to Rough	Stainless	G Class	CBN							
								RP (4)	MS (4)	MJ (4)	(4)			
Order Number	Stock	Insert Number	Dimensions (inch)										*2	
			H	B	LF	LH	HF	WF	Shim	Shim Pin	Clamp Bridge	Spring	Clamp Screw	Wrench
DDPNN-164	●	DNMA DNMG DNMM DNGA DNGG DNGM 43	1.000	1.000	6.000	1.500	1.000	.500	LLSDN43 *1 (LLSDN42)	LLP24 *1 (LLP14)	DCK2613	DCS1	DC0621T	TKY20F

*1 Please use shim no.LLSDN42 and shim pin LLP14 with .25inch thick insert. When using .25inch thick inserts, the shim and shim pin must be ordered separately.
 *2 Clamp Torque (lbf-in) : DC0621T=44

MDPN		External turning Copying		Multiple Clamp Type					Finish	Light	Medium	Medium			
												FH (4)	LP (4)	MP (4)	MK (4)
				Medium to Rough	Stainless	G Class	CBN								
								RP (4)	MS (4)	MJ (4)	(4)	(4)			
Order Number	Stock	Insert Number	Dimensions (inch)									*2			
			H	B	LF	LH	HF	WF	Shim	Shim Pin	Clamp Bridge	Clamp Screw			
MDPNN-164D	●	DNMA DNMG DNMM DNGA DNGG DNGM 43	1.000	1.000	6.000	1.750	1.000	.500	IDSN433	NL46	CL12	XNS510			
MDPNN-165D	●	DNMA DNMG DNMM DNGA DNGG DNGM 54	1.000	1.000	6.000	1.922	1.000	.500	IDSN533 *1	NL58	CL12	XNS510			

*1 (Opt.) See page M009 for different thickness.
 *2 Clamp Torque (lbf-in) : XNS510=70

DDPN type inserts > A103–A109
 MDPN type inserts > A103–A109
 CBN & PCD inserts > B024–B026, B051

CUTTING CONDITIONS > A074
 SPARE PARTS > M001
 TECHNICAL DATA > N001







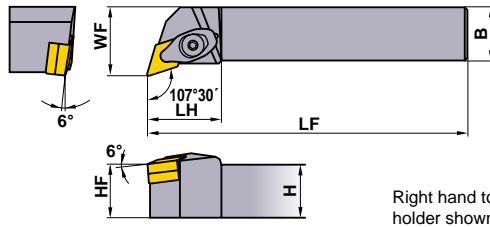
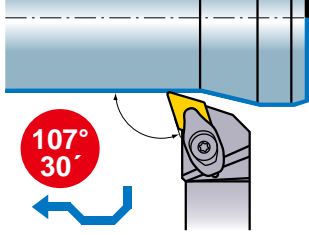

DN⁰⁰ INSERTS TOOL HOLDERS

DDQN







External turning **DOUBLE CLAMP Type**
Copying



Right hand tool holder shown.

Finish	Light	Medium	Medium
FH  (4)	LP  (4)	MP  (4)	MK  (4)
Medium to Rough	Stainless	G Class	CBN
RP  (4)	MS  (4)	MJ  (4)	 (4)

EXTERNAL TURNING TOOLS

Order Number	Stock		Insert Number	Dimensions (inch)										 *2	
	R	L		H	B	LF	LH	HF	WF	Shim	Shim Pin	Clamp Bridge	Spring	Clamp Screw	Wrench
DDQNR/L-164	●	●	DNMA DNMG DNMM DNGA DNGG DNGM 43	1.000	1.000	6.000	1.375	1.000	1.250	LLSDN43 *1 (LLSDN42)	LLP24 *1 (LLP14)	DCK2613	DCS1	DC0621T	TKY20F

*1 Please use shim no.LLSDN42 and shim pin LLP14 with .25inch thick insert. When using .25inch thick inserts, the shim and shim pin must be ordered separately.
*2 Clamp Torque (lbf-in) : DC0621T=44

(Note) Insert photo is an example. Letters show chip breaker style, figures show inscribed circle.

- : Inventory maintained.
- : Non stock, produced to order only.

DDQN type inserts	➤ A103–A109
CBN & PCD inserts	➤ B024–B026, B051
CUTTING CONDITIONS	➤ A074

RN INSERTS TOOL HOLDERS

DRGN				External turning Copying							DOUBLE CLAMP Type					Medium Standard		
Order Number	Stock		Insert Number	Dimensions (inch)						Shim	Shim Pin	Clamp Bridge	Spring	Clamp Screw*	Wrench	Medium Flat top		
	R	L		H	B	LF	LH	HF	WF							(4)		
DRGNR/L-124	●	●	43	.750	.750	4.500	1.188	.750	1.000	LLSRN42	LLP14	DCK2613	DCS1	DC0621T	TKY20F	(4)		
DRGNR/L-164	●	●		RNMG	1.000	1.000	6.000	1.188	1.000	1.250	LLSRN42	LLP14	DCK2613	DCS1	DC0621T	TKY20F	(4)	
DRGNR/L-204	●	●		43	1.250	1.250	6.000	1.188	1.250	1.500	LLSRN42	LLP14	DCK2613	DCS1	DC0621T	TKY20F	(4)	

* Clamp Torque (lbf-in) : DC0621T=44

EXTERNAL TURNING TOOLS

MRGN				External turning Copying							Multiple Clamp Type M Holder				Medium Standard	
Order Number	Stock		Insert Number	Dimensions (inch)						Shim	Shim Pin	Clamp Bridge	Clamp Screw*3	Medium Flat top		
	R	L		H	B	LF	LH	HF	WF					(4)		
MRGNR/L-123B	□	●	32	.750	.750	4.500	.937	.750	1.000	IRSN32	NL33	CL6	XNS36	(3,4,6)		
MRGNR/L-124B	●	□		43 *1 *2	.750	.750	4.500	1.187	.750	1.000	IRSN43 *1	NL46	CL9	XNS59	(4)	
MRGNR/L-163	□	□		32	1.000	1.000	6.000	.937	1.000	1.250	IRSN32	NL34	CL6	XNS36	(4)	
MRGNR/L-164C	●	●		43 *1 *2	1.000	1.000	5.000	1.187	1.000	1.250	IRSN43 *1	NL46	CL9	XNS59	(4)	
MRGNR/L-164D	●	●		43 *1 *2	1.000	1.000	6.000	1.187	1.000	1.250	IRSN43 *1	NL46	CL9	XNS59	(4)	
MRGNR/L-204D	●	□		43 *1 *2	1.250	1.250	6.000	1.187	1.250	1.500	IRSN43 *1	NL46	CL9	XNS59	(4)	
MRGNR/L-206D	□	□		64	1.250	1.250	6.000	1.125	1.250	1.500	IRSN63	NL68	CL12	XNS58	(4)	
MRGNR/L-246	□	□		64	1.500	1.500	7.000	1.125	1.500	2.000	IRSN63	NL68	CL12	XNS58	(4)	

*1 (Opt.) See page M009 for different thickness.

*2 For inserts without hole, remove shim pin and add below.

*3 Clamp Torque (lbf-in) : XNS36=30, XNS58=70, XNS59=70

Shim Screw	Chipbreaker
S46	CBR4

DRGN type inserts > A110
MRGN type inserts > A110

CUTTING CONDITIONS > A074
SPARE PARTS > M001
TECHNICAL DATA > N001

SN TOOL HOLDERS

EXTERNAL TURNING TOOLS

DSRN DOUBLE CLAMP Type

External turning

Finish	Light	Medium	Medium
FH (4)	LP (4)	MP (4)	MK (4)
Medium to Rough	Stainless	CBN	
RP (4)	MS (4)		

Order Number	Stock		Insert Number	Dimensions (inch)						Accessories					
	R	L		H	B	LF	LH	HF	WF	Shim	Shim Pin	Clamp Bridge	Spring	Clamp Screw*	Wrench
DSRNR/L-124	●	●	SNMA SNMG SNMM SNGA SNGG 43	.750	.750	4.500	1.250	.750	.878	LLSSN42	LLP14	DCK2613	DCS1	DC0621T	TKY20F
DSRNR/L-164	●	●	43	1.000	1.000	6.000	1.250	1.000	1.128	LLSSN42	LLP14	DCK2613	DCS1	DC0621T	TKY20F

* Clamp Torque (lbf-in) : DC0621T=44

MSRN Multiple Clamp Type M Holder

External turning

Finish	Light	Medium	Medium
FH (3,4)	LP (4)	MP (4)	MK (4,6)
Medium to Rough	Stainless	CBN	
RP (4)	MS (4,5)		

Order Number	Stock		Insert Number	Dimensions (inch)						Accessories				
	R	L		H	B	LF	LH	HF	WF	Shim	Shim Pin	Clamp Bridge	Clamp Screw*3	
MSRNR/L-83	□	□	SNMA SNMG SNMM SNGA SNGG	32 ^{*1} / _{*2}	.500	.500	4.500	1.062	.500	.658	ISSN322 ^{*1}	NL34	CL6	XNS36
MSRNR/L-103	□	□		32 ^{*1} / _{*2}	.625	.625	4.500	1.062	.625	.783	ISSN322 ^{*1}	NL34	CL6	XNS36
MSRNR/L-123	●	●		32 ^{*1} / _{*2}	.750	.750	4.500	1.062	.750	.908	ISSN322 ^{*1}	NL34	CL6	XNS36
MSRNR/L-124B	●	●		43 ^{*1} / _{*2}	.750	.750	4.500	1.234	.750	.878	ISSN433 ^{*1}	NL46	CL9	XNS59
MSRNR/L-164C	●	●		43 ^{*1} / _{*2}	1.000	1.000	5.000	1.234	1.000	1.128	ISSN433 ^{*1}	NL46	CL9	XNS59
MSRNR/L-164D	●	●		43 ^{*1} / _{*2}	1.000	1.000	6.000	1.234	1.000	1.128	ISSN433 ^{*1}	NL46	CL9	XNS59
MSRNR/L-165	●	●		54	1.000	1.000	6.000	1.343	1.000	1.100	ISSN533	NL58	CL12	XNS510
MSRNR/L-165C	●	●		54	1.000	1.000	5.000	1.343	1.000	1.100	ISSN533	NL58	CL12	XNS510
MSRNR/L-166	●	●		64 ^{*1}	1.000	1.000	6.000	1.500	1.000	1.068	ISSN633 ^{*1}	NL68	CL12	XNS510
MSRNR/L-205D	●	●		54	1.250	1.250	6.000	1.343	1.250	1.350	ISSN533	NL58	CL12	XNS510
MSRNR/L-206D	●	●		64 ^{*1}	1.250	1.250	6.000	1.500	1.250	1.312	ISSN633 ^{*1}	NL68	CL12	XNS510
MSRNR/L-246D	●	●		64 ^{*1}	1.500	1.500	6.000	1.500	1.500	1.818	ISSN633 ^{*1}	NL68	CL12	XNS510
MSRNR/L-246E	●	●		64 ^{*1}	1.500	1.500	7.000	1.500	1.500	1.818	ISSN633 ^{*1}	NL68	CL12	XNS510
MSRNR/L-248	●	●		86	1.500	1.500	7.000	1.625	1.500	1.768	ISSN846	NL810	CL24	XNS610

*1 (Opt.) See page M010 for different thickness or radius.
*2 For inserts without hole, remove shim pin and add below.
*3 Clamp Torque (lbf-in) : XNS36=30, XNS59=70, XNS510=70, XNS610=135

Insert	Shim Screw	Chippbreaker
SN [○] N3 [○]	S34	CBS3
SN [○] N4 [○]	S46	CBS4

(Note) Insert photo is an example. Letters show chip breaker style, figures show inscribed circle.

● : Inventory maintained.
□ : Non stock, produced to order only.

DSRN type inserts > A111-A116
MSRN type inserts > A111-A116

CBN & PCD inserts > B027, B052
CUTTING CONDITIONS > A074

DSSN

External turning Chamfering *DOUBLE CLAMP Type*

Order Number	Stock		Insert Number	Dimensions (inch)						Shim Shim Pin Clamp Bridge Spring Clamp Screw* Wrench						
	R	L		H	B	LF	LH	HF	WF	Shim	Shim Pin	Clamp Bridge	Spring	Clamp Screw	Wrench	
DSSNR/L-124	●	●	SNMA SNMG SNMM SNGA SNGG	43	.750	.750	4.500	1.250	.750	.659	LLSSN42	LLP14	DCK2613	DCS1	DC0621T	TKY20F
DSSNR/L-164	●	●		43	1.000	1.000	6.000	1.250	1.000	.909	LLSSN42	LLP14	DCK2613	DCS1	DC0621T	TKY20F

* Clamp Torque (lbf-in) : DC0621T=44

MSSN

External turning Chamfering *Multiple Clamp Type M Holder*

Order Number	Stock		Insert Number	Dimensions (inch)						Shim Shim Pin Clamp Bridge Clamp Screw*3				
	R	L		H	B	LF	LH	HF	WF	Shim	Shim Pin	Clamp Bridge	Clamp Screw	
MSSNR/L-83	<input type="checkbox"/>	<input type="checkbox"/>	SNMA SNMG SNMM SNGA SNGG	32 ^{*1} / _{*2}	.500	.500	4.500	1.062	.500	.391	ISSN322 ^{*1}	NL34	CL6	XNS36
MSSNR/L-124B	●	<input type="checkbox"/>		43 ^{*1} / _{*2}	.750	.750	4.500	1.234	.750	.662	ISSN433 ^{*1}	NL46	CL9	XNS59
MSSNR/L-164C	<input type="checkbox"/>	<input type="checkbox"/>		43 ^{*1} / _{*2}	1.000	1.000	5.000	1.234	1.000	.912	ISSN433 ^{*1}	NL46	CL9	XNS59
MSSNR/L-164D	●	●		43 ^{*1} / _{*2}	1.000	1.000	6.000	1.234	1.000	.912	ISSN433 ^{*1}	NL46	CL9	XNS59
MSSNR/L-205D	<input type="checkbox"/>	<input type="checkbox"/>		54	1.250	1.250	6.000	1.375	1.250	1.078	ISSN533	NL58	CL9	XNS510
MSSNR/L-206D	<input type="checkbox"/>	<input type="checkbox"/>		64 ^{*1}	1.250	1.250	6.000	1.484	1.250	.992	ISSN633 ^{*1}	NL68	CL9	XNS510

*1 (Opt.) See page M010 for different thickness or radius.

*2 For inserts without hole, remove shim pin and add below.

*3 Clamp Torque (lbf-in) : XNS36=30, XNS59=70, XNS510=70

Insert	Shim Screw	Chipbreaker
SN [○] N3 [○]	S34	CBS3D
SN [○] N4 [○]	S46	CBS4D

- | | |
|--------------------|--------------|
| DSSN type inserts | ➤ A111-A116 |
| MSSN type inserts | ➤ A111-A116 |
| CBN & PCD inserts | ➤ B027, B052 |
| CUTTING CONDITIONS | ➤ A074 |
| SPARE PARTS | ➤ M001 |
| TECHNICAL DATA | ➤ N001 |

SN INSERTS TOOL HOLDERS

EXTERNAL TURNING TOOLS

45°

External turning Chamfering *DOUBLE CLAMP Type*

Finish	Light	Medium	Medium
FH (4)	LP (4)	MP (4)	MK (4)
Medium to Rough	Stainless	CBN	
RP (4)	MS (4)		

Order Number	Stock	Insert Number	Dimensions (inch)												
			H	B	LF	LH	HF	WF	Shim	Shim Pin	Clamp Bridge	Spring	Clamp Screw	Wrench	
DSDNN-124	●	SNMA SNMG SNMM SNGA SNGG	43	.750	.750	4.500	1.375	.750	.375	LLSSN42	LLP14	DCK2613	DCS1	DC0621T	TKY20F
DSDNN-164	●	SNMA SNMG SNMM SNGA SNGG	43	1.000	1.000	6.000	1.375	1.000	.500	LLSSN42	LLP14	DCK2613	DCS1	DC0621T	TKY20F

* Clamp Torque (lbf-in) : DC0621T=44

45°

External turning Chamfering *Multiple Clamp Type M Holder*

Finish	Light	Medium	Medium
FH (3,4)	LP (4)	MP (4)	MK (4,5,6)
Medium to Rough	Stainless	CBN	
GH (4,5,6)	MS (3,4,5,6)		

Order Number	Stock	Insert Number	Dimensions (inch)										
			H	B	LF	LH	HF	WF	Shim	Shim Pin	Clamp Bridge	Clamp Screw	
MSDNN-83	●	SNMA SNMG SNMM SNGA SNGG	32 ^{*1} / _{*2}	.500	.500	4.500	1.000	.500	.250	ISSN322 ^{*1}	NL34	CL6	XNS36
MSDNN-103	□		32 ^{*1} / _{*2}	.625	.625	4.500	1.000	.625	.313	ISSN322 ^{*1}	NL34	CL6	XNS36
MSDNN-123	●		32 ^{*1} / _{*2}	.750	.750	4.500	1.000	.750	.375	ISSN322 ^{*1}	NL34	CL6	XNS36
MSDNN-124	●		43 ^{*1} / _{*2}	.750	.750	4.500	1.375	.750	.375	ISSN433 ^{*1}	NL46	CL9	XNS59
MSDNN-164	●		43 ^{*1} / _{*2}	1.000	1.000	6.000	1.375	1.000	.500	ISSN433 ^{*1}	NL46	CL9	XNS59
MSDNN-165	●		54 ^{*1}	1.000	1.000	6.000	1.625	1.000	.500	ISSN533 ^{*1}	NL58	CL12	XNS510
MSDNN-166	●		64 ^{*1}	1.000	1.000	6.000	1.625	1.000	.500	ISSN633 ^{*1}	NL68	CL12	XNS510
MSDNN-206	●		64 ^{*1}	1.250	1.250	7.000	1.625	1.250	.625	ISSN633 ^{*1}	NL68	CL12	XNS510

*1 (Opt.) See page M010 for different thickness or radius.

*2 For inserts without hole, remove shim pin and add below.

*3 Clamp Torque (lbf-in) : XNS36=30, XNS59=70, XNS510=70







Insert	Shim Screw	Chipbreaker
SN [○] N3 [○]	S34	CBS3D
SN [○] N4 [○]	S46	CBS4D

(Note) Insert photo is an example. Letters show chip breaker style, figures show inscribed circle.





- : Inventory maintained.
- : Non stock, produced to order only.

DSDN type inserts > A111-A116
MSDN type inserts > A111-A116

CBN & PCD inserts > B027, B052
CUTTING CONDITIONS > A074

Order Number		Stock		Insert Number	Dimensions (inch)						     					
		R	L		H	B	LF	LH	HF	WF	Shim	Shim Pin	Clamp Bridge	Spring	Clamp Screw	Wrench
DSKNR/L-124	●	●	SNMA SNMG SNMM SNGA SNGG	43	.750	.750	4.500	1.000	.750	1.000	LLSSN42	LLP14	DCK2613	DCS1	DC0621T	TKY20F
DSKNR/L-164	●	●	SNMA SNMG SNMM SNGA SNGG	43	1.000	1.000	6.000	1.000	1.000	1.250	LLSSN42	LLP14	DCK2613	DCS1	DC0621T	TKY20F

* Clamp Torque (lbf-in) : DC0621T=44

Order Number		Stock		Insert Number	Dimensions (inch)						   			
		R	L		H	B	LF	LH	HF	WF	Shim	Shim Pin	Clamp Bridge	Clamp Screw
MSKNR/L-83	□	□	SNMA SNMG SNMM SNGA SNGG	32 [○] ₂ ^{*1}	.500	.500	4.500	1.000	.500	.625	ISSN322 ^{*1}	NL34	CL6	XNS36
MSKNR/L-103	□	□		32 [○] ₂ ^{*1}	.625	.625	4.500	1.000	.625	.750	ISSN322 ^{*1}	NL34	CL6	XNS36
MSKNR/L-123	□	□		32 [○] ₂ ^{*1}	.750	.750	4.500	1.000	.750	.875	ISSN322 ^{*1}	NL34	CL6	XNS36
MSKNR/L-124B	●	●		43 [○] ₂ ^{*1}	.750	.750	4.500	1.219	.750	1.000	ISSN433 ^{*1}	NL46	CL9	XNS59
MSKNR/L-164D	●	●		43 [○] ₂ ^{*1}	1.000	1.000	6.000	1.219	1.000	1.250	ISSN433 ^{*1}	NL46	CL9	XNS59
MSKNR/L-165D	●	●		54 [○] ₁ ^{*1}	1.000	1.000	6.000	1.344	1.000	1.250	ISSN533	NL58	CL12	XNS510
MSKNR/L-205D	●	●		54 [○] ₁ ^{*1}	1.250	1.250	6.000	1.344	1.250	1.500	ISSN533	NL58	CL12	XNS510
MSKNR/L-206D	□	□		64 [○] ₁ ^{*1}	1.250	1.250	6.000	1.500	1.250	1.500	ISSN633	NL68	CL12	XNS510

*1 (Opt.) See page M010 for different thickness or radius.

*2 For inserts without hole, remove shim pin and add below.

*3 Clamp Torque (lbf-in) : XNS36=30, XNS59=70, XNS510=70

Insert	Shim Screw	Chipbreaker
SN [○] N3 [○]	S34	CBS3
SN [○] N4 [○]	S46	CBS4

DSKN type inserts	➤ A111-A116	CUTTING CONDITIONS	➤ A074
MSKN type inserts	➤ A111-A116	SPARE PARTS	➤ M001
CBN & PCD inserts	➤ B027, B052	TECHNICAL DATA	➤ N001

TN INSERTS TOOL HOLDERS

EXTERNAL TURNING TOOLS

MTJN

93°

Multiple Clamp Type
External turning **M** Holder

Right hand tool holder shown.

Finish	Light	Medium	Medium
FH (3)	LP (3)	MP (3,4)	MK (3,4)
Medium to Rough	Medium to Rough	Stainless	CBN
GH (3,4,5,6)	RP (3)	MS (3,4)	 (3)

Order Number	Stock		Insert Number	Dimensions (inch)						Shim Shim Pin Clamp Bridge Clamp Screw *2				
	R	L		H	B	LF	LH	HF	WF	Shim	Shim Pin	Clamp Bridge	Clamp Screw	
MTJNR/L-123X	●	●	TNMA TNMG TNMX TNMM TNGA TNGG	33 [○] *1	.750	.750	4.500	1.000	.750	1.000	ITSN323 ^{*1}	NL34L	CL6	XNS36
MTJNR/L-163X	●	●		33 [○] *1	1.000	1.000	6.000	1.000	1.000	1.250	ITSN323 ^{*1}	NL34L	CL6	XNS36
MTJNR/L-164	●	●		43 [○] *1	1.000	1.000	6.000	1.200	1.000	1.250	ITSN432 ^{*1}	NL46	CL9	XNS510
MTJNR/L-165	□	●		54 [○] *1	1.000	1.000	6.000	1.375	1.000	1.250	ITSN533 ^{*1}	NL58	CL9	XNS510
MTJNR/L-204	●	●		43 [○] *1	1.250	1.250	6.000	1.200	1.250	1.500	ITSN432 ^{*1}	NL46	CL9	XNS510
MTJNR/L-205	●	●		54 [○] *1	1.250	1.250	6.000	1.375	1.250	1.500	ITSN533 ^{*1}	NL58	CL9	XNS510
MTJNR/L-245	●	●		54 [○] *1	1.500	1.500	7.000	1.375	1.500	2.000	ITSN533 ^{*1}	NL58	CL9	XNS510
MTJNR/L-246	●	□		66 [○] *1	1.500	1.500	7.000	1.375	1.500	2.000	ITSN636 ^{*1}	NL68L	CL12	XNS510
MTJNR/L-854	●	□		43 [○] *1	1.250	1.000	6.000	1.200	1.250	1.250	ITSN432 ^{*1}	NL46	CL9	XNS510

*1 (Opt.) See page M010 for different thickness or radius.

*2 Clamp Torque (lbf-in) : XNS36=30, XNS510=70

DTGN

91°

DOUBLE CLAMP Type
External turning

Right hand tool holder shown.

Finish	Light	Medium	Medium
FH (3)	LP (3)	MP (3,4)	MK (3)
Medium to Rough	Stainless	CBN	
RP (3,4)	MS (3,4)	 (3)	

Order Number	Stock		Insert Number	Dimensions (inch)						Shim Shim Pin Clamp Bridge Spring Clamp Screw *2 Wrench						
	R	L		H	B	LF	LH	HF	WF	Shim	Shim Pin	Clamp Bridge	Spring	Clamp Screw	Wrench	
DTGNR/L-123	●	●	TNMA TNMG TNMM TNGA TNGG	33 [○]	.750	.750	4.500	1.000	.750	1.000	LLSTN32 ^{*1} (LLSTN33)	LLP23	DCK2211	DCS2	DC0520T	TKY15F
DTGNR/L-163	●	●		33 [○]	1.000	1.000	6.000	1.000	1.000	1.250	LLSTN32 ^{*1} (LLSTN33)	LLP23	DCK2211	DCS2	DC0520T	TKY15F
DTGNR/L-164	●	●		43 [○]	1.000	1.000	6.000	1.250	1.000	1.250	LLSTN42	LLP14	DCK2613	DCS1	DC0621T	TKY20F
DTGNR/L-204	●	●		43 [○]	1.250	1.250	6.000	1.250	1.250	1.500	LLSTN42	LLP14	DCK2613	DCS1	DC0621T	TKY20F
DTGNR/L-244	●	●		43 [○]	1.500	1.500	6.000	1.250	1.500	2.000	LLSTN42	LLP14	DCK2613	DCS1	DC0621T	TKY20F

*1 Please use shim no.LLSTN33 with .125inch thick insert. When using .125inch thick inserts, the shim must be ordered separately.

*2 Clamp Torque (lbf-in) : DC0520T=31, DC0621T=44

(Note) Insert photo is an example. Letters show chip breaker style, figures show inscribed circle.

● : Inventory maintained.
□ : Non stock, produced to order only.

MTJN type inserts > A117-A123
DTGN type inserts > A117-A123

CBN & PCD inserts > B028, B029, B052
CUTTING CONDITIONS > A074

MTGN

Multiple Clamp Type External turning M Holder

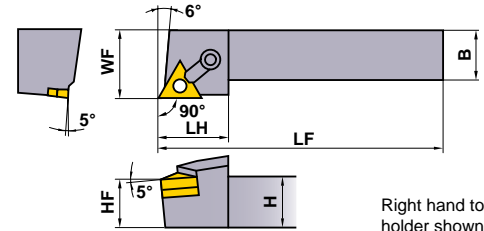
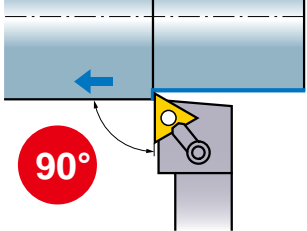

Right hand tool holder shown.

Finish	Light	Medium	Medium
FH	LP	MP	MK
(3)	(3)	(3,4)	(3,4)
Medium to Rough	Medium to Rough	Stainless	CBN
GH	RP	MS	
(3,4,5,6)	(3)	(3,4)	(3)

Order Number	Stock		Insert Number	Dimensions (inch)										
	R	L		H	B	LF	LH	HF	WF	Shim	Shim Pin	Clamp Bridge	Clamp Screw	
MTGNR/L-123BX	●	●	TNMA TNMG TNMM TNGA TNGG	33 ^{*1} _{*2}	.750	.750	4.500	.937	.750	1.000	ITSN323 ^{*1}	NL34L	CL6	XNS36
MTGNR/L-163CX	●	●		33 ^{*1} _{*2}	1.000	1.000	5.000	.937	1.000	1.250	ITSN323 ^{*1}	NL34L	CL6	XNS36
MTGNR/L-163DX	□	●		33 ^{*1} _{*2}	1.000	1.000	6.000	.937	1.000	1.250	ITSN323 ^{*1}	NL34L	CL9	XNS36
MTGNR/L-164C	●	●		43 ^{*1}	1.000	1.000	5.000	1.200	1.000	1.250	ITSN432 ^{*1}	NL46	CL9	XNS510
MTGNR/L-164D	●	●		43 ^{*1}	1.000	1.000	6.000	1.200	1.000	1.250	ITSN432 ^{*1}	NL46	CL9	XNS510
MTGNR/L-165C	□	□		54 ^{*1}	1.000	1.000	5.000	1.375	1.000	1.250	ITSN533 ^{*1}	NL58	CL9	XNS510
MTGNR/L-165D	□	□		54 ^{*1}	1.000	1.000	6.000	1.375	1.000	1.250	ITSN533 ^{*1}	NL58	CL9	XNS510
MTGNR/L-204D	□	●		43 ^{*1}	1.250	1.250	6.000	1.187	1.250	1.500	ITSN432 ^{*1}	NL46	CL9	XNS510
MTGNR/L-205D	●	□		54 ^{*1}	1.250	1.250	6.000	1.375	1.250	1.500	ITSN533 ^{*1}	NL58	CL9	XNS510
MTGNR/L-244D	□	□		43 ^{*1}	1.500	1.500	6.000	1.375	1.500	2.000	ITSN432 ^{*1}	NL46	CL9	XNS510
MTGNR/L-244E	□	□		43 ^{*1}	1.500	1.500	7.000	1.375	1.500	2.000	ITSN432 ^{*1}	NL46	CL9	XNS510
MTGNR/L-245D	□	□		54 ^{*1}	1.500	1.500	6.000	1.375	1.500	2.000	ITSN533 ^{*1}	NL58	CL9	XNS510
MTGNR/L-245E	□	□		54 ^{*1}	1.500	1.500	7.000	1.375	1.500	2.000	ITSN533 ^{*1}	NL58	CL9	XNS510
MTGNR/L-246D	□	□		66 ^{*1}	1.500	1.500	6.000	1.500	1.500	2.000	ITSN636 ^{*1}	NL68L	CL12	XNS510
MTGNR/L-246E	□	□		66 ^{*1}	1.500	1.500	7.000	1.500	1.500	2.000	ITSN636 ^{*1}	NL68L	CL12	XNS510
MTGNR/L-854D	□	□		43 ^{*1}	1.250	1.000	6.000	1.200	1.250	1.250	ITSN432 ^{*1}	NL46	CL9	XNS510
MTGNR/L-855D	●	□		54 ^{*1}	1.250	1.000	6.000	1.375	1.250	1.250	ITSN533 ^{*1}	NL58	CL9	XNS510

*1 (Opt.) See page M010 for different thickness or radius.

*3 Clamp Torque (lbf-in) : XNS36=30, XNS510=70

*2 For inserts without hole, remove shim pin and add below.

Shim Screw	Chipbreaker
S34	CBT3

EXTERNAL TURNING TOOLS

MTGN type inserts > A117-A123
 CBN & PCD inserts > B028, B029, B052
 CUTTING CONDITIONS > A074

SPARE PARTS > M001
 TECHNICAL DATA > N001

TN INSERTS TOOL HOLDERS

EXTERNAL TURNING TOOLS

MTAN

Multiple Clamp Type
External turning **M** Holder

Right hand tool holder shown.

Finish	Light	Medium	Medium
FH (3)	LP (3)	MP (3,4)	MK (3,4)
Medium to Rough	Medium to Rough	Stainless	CBN
GH (3,4,5,6)	RP (3)	MS (3,4)	 (3)

Order Number	Stock		Insert Number	Dimensions (inch)						Shim	Shim Pin	Clamp Bridge	Clamp Screw ^{*3}	
	R	L		H	B	LF	LH	HF	WF					
MTANR/L-102	<input type="checkbox"/>	<input type="checkbox"/>	TNMA TNMG TNMM TNGA TNGG	22 [○]	.625	.625	4.500	.875	.625	.625	—	NL23	CL19	XNS36
MTANR/L-103X	<input checked="" type="checkbox"/>	<input type="checkbox"/>		33 [○] *1*2	.625	.625	4.500	1.000	.625	.625	ITSN323 ^{*1}	NL34L	CL6	XNS36
MTANR/L-123X	<input checked="" type="checkbox"/>	<input type="checkbox"/>		33 [○] *1*2	.750	.750	4.500	1.000	.750	.750	ITSN323 ^{*1}	NL34L	CL6	XNS36
MTANR/L-163X	<input checked="" type="checkbox"/>	<input checked="" type="checkbox"/>		33 [○] *1*2	1.000	1.000	6.000	1.000	1.000	1.000	ITSN323 ^{*1}	NL34L	CL6	XNS36
MTANR/L-164	<input checked="" type="checkbox"/>	<input checked="" type="checkbox"/>		43 [○] *1	1.000	1.000	6.000	1.218	1.000	1.000	ITSN432 ^{*1}	NL46	CL9	XNS59
MTANR/L-165	<input checked="" type="checkbox"/>	<input type="checkbox"/>		54 [○] *1	1.000	1.000	6.000	1.375	1.000	1.000	ITSN533 ^{*1}	NL58	CL9	XNS510
MTANR/L-204	<input checked="" type="checkbox"/>	<input checked="" type="checkbox"/>		43 [○] *1	1.250	1.250	7.000	1.218	1.250	1.250	ITSN432 ^{*1}	NL46	CL9	XNS59
MTANR/L-205	<input checked="" type="checkbox"/>	<input type="checkbox"/>		54 [○] *1	1.250	1.250	7.000	1.375	1.250	1.250	ITSN533 ^{*1}	NL58	CL9	XNS510
MTANR/L-246	<input type="checkbox"/>	<input type="checkbox"/>		66 [○] *1	1.500	1.500	7.000	1.484	1.500	1.500	ITSN636 ^{*1}	NL68L	CL12	XNS510
MTANR/L-864	<input type="checkbox"/>	<input type="checkbox"/>		43 [○] *1	1.500	1.000	7.000	1.218	1.500	1.000	ITSN432 ^{*1}	NL46	CL9	XNS59

*1 (Opt.) See page M010 for different thickness or radius.

*2 For inserts without hole, remove shim pin and add below.

*3 Clamp Torque (lbf-in) : XNS36=30, XNS59=70, XNS510=70

Shim Screw	Chipbreaker
S34	CBT3

MTRN

Multiple Clamp Type
External turning **M** Holder

Right hand tool holder shown.

Finish	Light	Medium	Medium
FH (3)	LP (3)	MP (3,4)	MK (3,4)
Medium to Rough	Stainless	CBN	
RP (3)	MS (3,4)	 (3)	

Order Number	Stock		Insert Number	Dimensions (inch)						Shim	Shim Pin	Clamp Bridge	Clamp Screw ^{*3}	
	R	L		H	B	LF	LH	HF	WF					
MTRNR/L-123X	<input type="checkbox"/>	<input type="checkbox"/>	TNMA TNMG TNMM TNGA TNGG	33 [○] *1*2	.750	.750	4.500	1.203	.750	.897	ITSN323 ^{*1}	NL34L	CL20	XNS46
MTRNR/L-164	<input type="checkbox"/>	<input type="checkbox"/>		43 [○] *1	1.000	1.000	6.000	1.250	1.000	1.040	ITSN432 ^{*1}	NL46	CL9	XNS510

*1 (Opt.) See page M010 for different thickness or radius.

*2 For inserts without hole, remove shim pin and add below.

*3 Clamp Torque (lbf-in) : XNS46=45, XNS510=70

Shim Screw	Chipbreaker
S34	CBT3

(Note) Insert photo is an example. Letters show chip breaker style, figures show inscribed circle.

● : Inventory maintained.

□ : Non stock, produced to order only.

MTAN type inserts > A117-A123
MTRN type inserts > A117-A123

CBN & PCD inserts > B028, B029, B052
CUTTING CONDITIONS > A074

MTEN		External turning Chamfering		Multiple Clamp Type M Holder		Finish	Light	Medium	Medium				
						FH	LP	MP	MK				
						(3)	(3)	(3,4)	(3,4)				
						Medium to Rough	Stainless	CBN					
						RP	MS						
(3)	(3,4)	(3)											
Order Number	Stock	Insert Number		Dimensions (inch)								*2	
		H	B	LF	LH	HF	WF	Shim	Shim Pin	Clamp Bridge	Clamp Screw		
MTENN-82	●	TNMA TNMG TNMM TNGA TNGG	22 [○]	.500	.500	4.500	1.000	.500	.250	—	NL23	CL6	XNS36
MTENN-103X	●		33 [○] *1	.625	.625	4.500	1.156	.625	.313	ITSN323 ^{*1}	NL34L	CL6	XNS36
MTENN-123X	●		33 [○] *1	.750	.750	4.500	1.156	.750	.375	ITSN323 ^{*1}	NL34L	CL6	XNS36
MTENN-164	●		43 [○] *1	1.000	1.000	6.000	1.500	1.000	.500	ITSN432 ^{*1}	NL46	CL9	XNS59
MTENN-205	●		54 [○] *1	1.250	1.250	7.000	1.620	1.250	.625	ITSN533 ^{*1}	NL58	CL9	XNS510
MTENN-854	□		43 [○] *1	1.250	1.000	6.000	1.500	1.250	.500	ITSN432 ^{*1}	NL46	CL9	XNS59
MTENN-864	●		43 [○] *1	1.500	1.000	7.000	1.500	1.500	.500	ITSN432 ^{*1}	NL46	CL9	XNS59
MTENN-865	●		54 [○] *1	1.500	1.000	7.000	1.620	1.500	.500	ITSN533 ^{*1}	NL58	CL9	XNS510

*1 (Opt.) See page M010 for different thickness or radius.

*2 Clamp Torque (lbf-in) : XNS36=30, XNS59=70, XNS510=70

MTCN		Facing		Multiple Clamp Type M Holder		Finish	Light	Medium	Medium			
						FH	LP	MP	MK			
						(3)	(3)	(3,4)	(3,4)			
						Medium to Rough	Stainless	CBN				
						RP	MS					
(3)	(3,4)	(3)										
Order Number	Stock	Insert Number		Dimensions (inch)								*3
		H	B	LF	LH	HF	Shim	Shim Pin	Clamp Bridge	Clamp Screw		
MTCNN-83X	□	TNMA TNMG TNMM TNGA TNGG	33 [○] *1*2	.500	.500	4.500	1.125	.500	ITSN323 ^{*1}	NL34L	CL7	XNS36
MTCNN-124	□		43 [○] *1	.750	.750	4.500	1.375	.750	ITSN432 ^{*1}	NL46	CL12	XNS59
MTCNN-443X	□		33 [○] *1*2	1.000	.500	8.000	1.125	1.000	ITSN323 ^{*1}	NL34L	CL7	XNS36
MTCNN-644	□		43 [○] *1	1.000	.750	8.000	1.375	1.000	ITSN432 ^{*1}	NL46	CL12	XNS59
MTCNN-664	□		43 [○] *1	1.500	.750	8.000	1.375	1.500	ITSN432 ^{*1}	NL46	CL12	XNS59

*1 (Opt.) See page M010 for different thickness or radius.

*3 Clamp Torque (lbf-in) : XNS36=30, XNS59=70

*2 For inserts without hole, remove shim pin and add below.

Shim Screw	S34	Chippbreaker	CBT3
------------	-----	--------------	------

MTEN type inserts > A117-A123
MTCN type inserts > A117-A123
CBN & PCD inserts > B028, B029, B052
CUTTING CONDITIONS > A074

SPARE PARTS > M001
TECHNICAL DATA > N001

TN INSERTS TOOL HOLDERS

EXTERNAL TURNING TOOLS

DTFN

DOUBLE CLAMP Type

Facing

91°

WF 91°

LH

LF

HF 6°

H

Right hand tool holder shown.

Finish	Light	Medium	Medium
FH (3)	LP (3)	MP (3,4)	MK (3,4)
Medium to Rough	Stainless	CBN	
RP (3)	MS (3,4)	 (3)	

Order Number	Stock		Insert Number	Dimensions (inch)						Shim Shim Pin Clamp Bridge Spring Clamp Screw *2 Wrench						
	R	L		H	B	LF	LH	HF	WF	Shim	Shim Pin	Clamp Bridge	Spring	Clamp Screw	Wrench	
DTFNR/L-123	●	●	TNMA TNMG TNMM TNGA TNGG	33	.750	.750	4.500	1.000	.750	1.000	LLSTN32*1 (LLSTN33)	LLP23	DCK2211	DCS2	DC0520T	TKY15F
DTFNR/L-163	●	●		33	1.000	1.000	6.000	1.000	1.000	1.250	LLSTN32*1 (LLSTN33)	LLP23	DCK2211	DCS2	DC0520T	TKY15F
DTFNR/L-164	●	●		43	1.000	1.000	6.000	1.219	1.000	1.250	LLSTN42	LLP14	DCK2613	DCS1	DC0621T	TKY20F
DTFNR/L-204	●	●		43	1.250	1.250	6.000	1.219	1.250	1.500	LLSTN42	LLP14	DCK2613	DCS1	DC0621T	TKY20F

*1 Please use shim no.LLSTN33 with .125inch thick insert. When using .125inch thick inserts, the shim must be ordered separately.
 *2 Clamp Torque (lbf-in) : DC0520T=31, DC0621T=44

DTCN

DOUBLE CLAMP Type

Facing

90°

WF 90°

LH

LF

HF 7°

H

Finish	Light	Medium	Medium
FH (3)	LP (3)	MP (3)	MK (3)
Medium to Rough	Stainless	CBN	
RP (3)	MS (3)	 (3)	

Order Number	Stock		Insert Number	Dimensions (inch)						Shim Shim Pin Clamp Bridge Spring Clamp Screw *2 Wrench						
	R	L		H	B	LF	LH	HF	WF	Shim	Shim Pin	Clamp Bridge	Spring	Clamp Screw	Wrench	
DTCNN-433	●		TNMA TNMG TNMM TNGA TNGG	33	.750	.500	4.500	1.375	.750	.539	LLSTN32*1 (LLSTN33)	LLP23	DCK3113	DCS2	DC0520T	TKY15F
DTCNN-443	●			33	1.000	.500	6.000	1.375	1.000	.539	LLSTN32*1 (LLSTN33)	LLP23	DCK3113	DCS2	DC0520T	TKY15F

*1 Please use shim no.LLSTN33 with .125inch thick insert. When using .125inch thick inserts, the shim must be ordered separately.
 *2 Clamp Torque (lbf-in) : DC0520T=31

(Note) Insert photo is an example. Letters show chip breaker style, figures show inscribed circle.

● : Inventory maintained.

□ : Non stock, produced to order only.

DTFN type inserts > A117-A123
 DTCN type inserts > A117-A123

CBN & PCD inserts > B028, B029, B052
 CUTTING CONDITIONS > A074



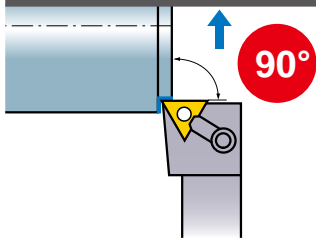

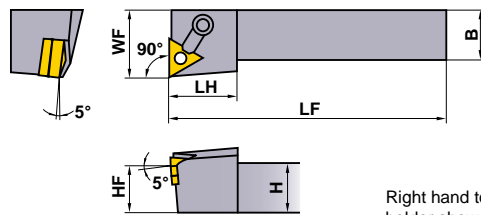

MTFN



Facing Multiple Clamp Type M Holder



Right hand tool holder shown.

Finish	Light	Medium	Medium
FH	LP	MP	MK
 (3)	 (3)	 (3,4)	 (3,4)
Medium to Rough	Stainless	CBN	
RP	MS		
 (3)	 (3,4)	 (3)	

Order Number	Stock		Insert Number	Dimensions (inch)						Shim	Shim Pin	Clamp Bridge	Clamp Screw ^{*3}	
	R	L		H	B	LF	LH	HF	WF					
MTFNR/L-82	<input type="checkbox"/>	<input type="checkbox"/>	TNMA TNMG TNMM TNGA TNGG	22 [○]	.500	.500	4.500	.813	.500	.750	—	NL23	CL19	XNS36
MTFNR/L-103X	<input type="checkbox"/>	<input type="checkbox"/>		33 [○] *1 *2	.625	.625	4.500	.875	.625	.875	ITSN323 ^{*1}	NL34L	CL6	XNS36
MTFNR/L-123BX	<input checked="" type="checkbox"/>	<input checked="" type="checkbox"/>		33 [○] *1 *2	.750	.750	4.500	.875	.750	1.000	ITSN323 ^{*1}	NL34L	CL6	XNS36
MTFNR/L-163CX	<input checked="" type="checkbox"/>	<input checked="" type="checkbox"/>		33 [○] *1 *2	1.000	1.000	5.000	.875	1.000	1.250	ITSN323 ^{*1}	NL34L	CL6	XNS36
MTFNR/L-163DX	<input type="checkbox"/>	<input type="checkbox"/>		33 [○] *1 *2	1.000	1.000	6.000	.875	1.000	1.250	ITSN323 ^{*1}	NL34L	CL6	XNS36
MTFNR/L-164C	<input type="checkbox"/>	<input type="checkbox"/>		43 [○] *1	1.000	1.000	5.000	1.218	1.000	1.250	ITSN432 ^{*1}	NL46	CL9	XNS510
MTFNR/L-164D	<input checked="" type="checkbox"/>	<input checked="" type="checkbox"/>		43 [○] *1	1.000	1.000	6.000	1.218	1.000	1.250	ITSN432 ^{*1}	NL46	CL9	XNS510
MTFNR/L-165C	<input type="checkbox"/>	<input type="checkbox"/>		54 [○] *1	1.000	1.000	5.000	1.375	1.000	1.250	ITSN533 ^{*1}	NL58	CL12	XNS510
MTFNR/L-165D	<input type="checkbox"/>	<input type="checkbox"/>		54 [○] *1	1.000	1.000	6.000	1.375	1.000	1.250	ITSN533 ^{*1}	NL58	CL12	XNS510
MTFNR/L-204D	<input type="checkbox"/>	<input type="checkbox"/>		43 [○] *1	1.250	1.250	6.000	1.218	1.250	1.500	ITSN432 ^{*1}	NL46	CL9	XNS510
MTFNR/L-205D	<input checked="" type="checkbox"/>	<input type="checkbox"/>		54 [○] *1	1.250	1.250	6.000	1.375	1.250	1.500	ITSN533 ^{*1}	NL58	CL12	XNS510
MTFNR/L-246D	<input type="checkbox"/>	<input type="checkbox"/>		66 [○] *1	1.500	1.500	6.000	1.500	1.500	2.000	ITSN636 ^{*1}	NL68	CL12	XNS510
MTFNR/L-246E	<input type="checkbox"/>	<input type="checkbox"/>		66 [○] *1	1.500	1.500	7.000	1.500	1.500	2.000	ITSN636 ^{*1}	NL68	CL12	XNS510
MTFNR/L-855D	<input type="checkbox"/>	<input type="checkbox"/>		54 [○] *1	1.250	1.000	6.000	1.375	1.250	1.250	ITSN533 ^{*1}	NL58	CL12	XNS510

*1 (Opt.) See page M010 for different thickness or radius.

*3 Clamp Torque (lbf-in) : XNS36=30, XNS510=70

*2 For inserts without hole, remove shim pin and add below.

Shim Screw	Chipbreaker
S34	CBT3

EXTERNAL TURNING TOOLS

MTFN type inserts > A117-A123

CBN & PCD inserts > B028, B029, B052

CUTTING CONDITIONS > A074

SPARE PARTS > M001

TECHNICAL DATA > N001

EXTERNAL TURNING TOOLS

VN INSERTS TOOL HOLDERS

EXTERNAL TURNING TOOLS

DVJN

93°

6°

External turning Copying **DOUBLE CLAMP Type**

Right hand tool holder shown.

Finish	Light	Medium	Medium
FH (3)	LP (3)	MA (3)	MK (3)
Medium	Stainless	G Class	CBN
MP (3)	MS (3)	MJ (3)	 (3)

Order Number	Stock		Insert Number	Dimensions (inch)						Shim Shim Pin Clamp Bridge Spring Clamp Screw * Wrench					
	R	L		H	B	LF	LH	HF	WF	Shim	Shim Pin	Clamp Bridge	Spring	Clamp Screw	Wrench
DVJNR/L-123	●	●	VNGA VNMG 33	.750	.750	4.500	1.625	.750	1.000	DCSVN32	LLP13	DCK3113	DCS2	DC0520T	TKY15F
DVJNR/L-163	●	●	VNGM VNGG 33	1.000	1.000	6.000	1.625	1.000	1.250	DCSVN32	LLP13	DCK3113	DCS2	DC0520T	TKY15F
DVJNR/L-203	●	●	VNMM 33	1.250	1.250	6.000	1.625	1.250	1.500	DCSVN32	LLP13	DCK3113	DCS2	DC0520T	TKY15F

* Clamp Torque (lbf-in) : DC0520T=31

MVJN

93°

5°

External turning Copying **Multiple Clamp Type M Holder**

Right hand tool holder shown.

Finish	Light	Medium	Medium
FH (3)	LP (3)	MA (3)	MK (3)
Medium	Stainless	G Class	CBN
MP (3)	MS (3)	MJ (3)	 (3)

Order Number	Stock		Insert Number	Dimensions (inch)						Shim Shim Pin Clamp Bridge Clamp Screw *2				
	R	L		H	B	LF	LH	HF	WF	Shim	Shim Pin	Clamp Bridge	Clamp Screw	
MVJNR/L-123B	●	●	VNGA VNMG VNGM VNGG VNMM	33	.750	.750	4.500	1.687	.750	1.000	IVSN322	NL34L	CL30	XNS510
MVJNR/L-163C	●	●		33	1.000	1.000	5.000	1.687	1.000	1.250	IVSN322	NL34L	CL30	XNS510
MVJNR/L-163D	●	●		33	1.000	1.000	6.000	1.687	1.000	1.250	IVSN322	NL34L	CL30	XNS510
MVJNR/L-164C	□	□		43	1.000	1.000	5.000	2.000	1.000	1.250	IVSN432*1	NL46	CL30	XNS510
MVJNR/L-164D	●	●		43	1.000	1.000	6.000	2.000	1.000	1.250	IVSN432*1	NL46	CL30	XNS510
MVJNR/L-203D	□	□		33	1.250	1.250	6.000	1.687	1.250	1.500	IVSN322	NL34L	CL30	XNS510
MVJNR/L-204D	□	□		43	1.250	1.250	6.000	2.000	1.250	1.500	IVSN432*1	NL46	CL30	XNS510

*1 (Opt.) See page M010 for different radius.

*2 Clamp Torque (lbf-in) : XNS510=70

(Note) Insert photo is an example. Letters show chip breaker style, figures show inscribed circle.

● : Inventory maintained.

□ : Non stock, produced to order only.

DVJN type inserts > A124-A127

MVJN type inserts > A124-A127

CBN & PCD inserts > B030, B031, B053

CUTTING CONDITIONS > A074

DVPN Facing Copying *DOUBLE CLAMP Type*

117° 30'

7°

Finish	Light	Medium	Medium
FH (3)	LP (3)	MA (3)	MK (3)
Medium	Stainless	G Class	CBN
MP (3)	MS (3)	MJ (3)	 (3)

Right hand tool holder shown.

Order Number	Stock		Insert Number	Dimensions (inch)												
	R	L		H	B	LF	LH	HF	WF	Shim	Shim Pin	Clamp Bridge	Spring	Clamp Screw	Wrench	
DVPCR/L-123	●	●	VNGA VNMG VNGM VNGG VNMM	33	.750	.750	4.500	1.250	.750	1.000	DCSVN32	LLP13	DCK3113	DCS2	DC0520T	TKY15F
DVPCR/L-163	●	●	VNGA VNMG VNGM VNGG VNMM	33	1.000	1.000	6.000	1.250	1.000	1.250	DCSVN32	LLP13	DCK3113	DCS2	DC0520T	TKY15F

* Clamp Torque (lbf-in) : DC0520T=31

DVVN External turning Copying *DOUBLE CLAMP Type*

72° 30'

16°

Finish	Light	Medium	Medium
FH (3)	LP (3)	MA (3)	MK (3)
Medium	Stainless	G Class	CBN
MP (3)	MS (3)	MJ (3)	 (3)

Order Number	Stock		Insert Number	Dimensions (inch)												
	R	L		H	B	LF	LH	HF	WF	Shim	Shim Pin	Clamp Bridge	Spring	Clamp Screw	Wrench	
DVVNN-123	●	●	VNGA VNMG VNGM VNGG VNMM	33	.750	.750	4.500	1.750	.750	.375	DCSVN32	LLP13	DCK3113	DCS2	DC0520T	TKY15F
DVVNN-163	●	●	VNGA VNMG VNGM VNGG VNMM	33	1.000	1.000	6.000	1.750	1.000	.500	DCSVN32	LLP13	DCK3113	DCS2	DC0520T	TKY15F

* Clamp Torque (lbf-in) : DC0520T=31

- DVPN type inserts > A124-A127
- DVNN type inserts > A124-A127
- CBN & PCD inserts > B030, B031, B053

- CUTTING CONDITIONS > A074
- SPARE PARTS > M001
- TECHNICAL DATA > N001

VN⁰⁰ INSERTS TOOL HOLDERS

MVLN

Facing

Multiple Clamp Type
M Holder

Medium
MJ

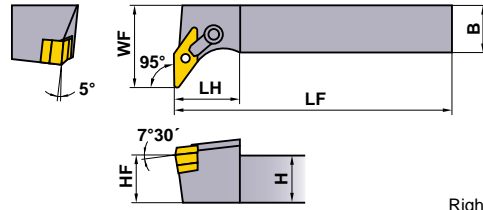
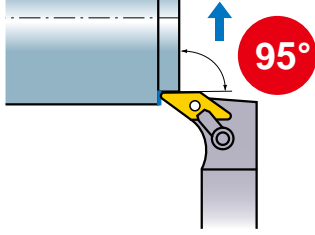

Right hand tool holder shown.

EXTERNAL TURNING TOOLS

Order Number	Stock		Insert Number	Dimensions (inch)									*2	
	R	L		H	B	LF	LH	HF	WF	Shim	Shim Pin	Clamp Bridge	Clamp Screw	
MVLNR/L-164C	●	●	VNGA VNMG VNGM	43 ⁰	1.000	1.000	5.000	1.500	1.000	1.750	IVSN432 ^{*1}	NL46	CL12	XNS510
MVLNR/L-164D	●	●		43 ⁰	1.000	1.000	6.000	1.500	1.000	1.750	IVSN432 ^{*1}	NL46	CL12	XNS510
MVLNR/L-204D	●	●		43 ⁰	1.250	1.250	6.000	1.500	1.250	2.000	IVSN432 ^{*1}	NL46	CL12	XNS510
MVLNR/L-244D	□	□		43 ⁰	1.500	1.500	6.000	1.500	1.500	2.250	IVSN432 ^{*1}	NL46	CL12	XNS510

*1 (Opt.) See page M010 for different radius.

*2 Clamp Torque (lbf-in) : XNS510=70

(Note) Insert photo is an example. Letters show chip breaker style, figures show inscribed circle.

WNO INSERTS TOOL HOLDERS

DWLN

External turning Facing **DOUBLE CLAMP Type**

95°

Right hand tool holder shown.

Finish	Light	Medium	Medium
FH (4)	LP (4)	MP (3,4)	MK (4)
Medium Standard (4)	Medium to Rough RP (4)	Stainless MS (3,4)	

Order Number	Stock		Insert Number	Dimensions (inch)						Tools						
	R	L		H	B	LF	LH	HF	WF	Shim	Shim Pin	Clamp Bridge	Spring	Clamp Screw	Wrench	
DWLN/L-123	●	●	WNMA WNMG	33	.750	.750	4.500	1.000	.750	1.000	LLSWN32 (LLSWN33)*1	LLP23	DCK2211	DCS2	DC0520T	TKY15F
DWLN/L-124	●	●		43	.750	.750	4.500	1.250	.750	1.000	LLSWN42	LLP14	DCK2613	DCS1	DC0621T	TKY20F
DWLN/L-163	●	●		33	1.000	1.000	6.000	1.000	1.000	1.250	LLSWN32 (LLSWN33)*1	LLP23	DCK2211	DCS2	DC0520T	TKY15F
DWLN/L-164	●	●		43	1.000	1.000	6.000	1.250	1.000	1.250	LLSWN42	LLP14	DCK2613	DCS1	DC0621T	TKY20F
DWLN/L-204	●	●		43	1.250	1.250	6.000	1.250	1.250	1.500	LLSWN42	LLP14	DCK2613	DCS1	DC0621T	TKY20F

*1 Please use shim no.LLSWN33 with .125inch thick insert. When using .125inch thick inserts, the shim must be ordered separately.

*2 Clamp Torque (lbf-in) : DC0520T=31, DC0621T=44

MWLN

External turning Facing **Multiple Clamp Type M Holder**

95°

Right hand tool holder shown.

Finish	Light	Medium	Medium
FH (4)	SA (4)	MA (3,4)	MK (4)
Medium Standard (4)	Medium to Rough RP (4)	Stainless MS (3,4)	

Order Number	Stock		Insert Number	Dimensions (inch)						Tools				
	R	L		H	B	LF	LH	HF	WF	Shim	Shim Pin	Clamp Bridge	Clamp Screw	
MWLN/L-1232	●	●	WNMA WNMG	32	.750	.750	4.500	1.000	.750	1.000	IWSN322	NL34L	CL7	XNS36
MWLN/L-1233	●	●		33	.750	.750	4.500	1.000	.750	1.000	IWSN322	NL34L	CL7	XNS36
MWLN/L-124B	●	●		43	.750	.750	4.500	1.000	.750	1.000	IWSN432	NL46	CL20	XNS48
MWLN/L-1632	●	●		32	1.000	1.000	6.000	1.188	1.000	1.250	IWSN322	NL34	CL7	XNS36
MWLN/L-1633	●	●		33	1.000	1.000	6.000	1.188	1.000	1.250	IWSN322	NL34L	CL7	XNS36
MWLN/L-164D	●	●		43	1.000	1.000	6.000	1.188	1.000	1.250	IWSN432	NL46	CL20	XNS48
MWLN/L-854D	●	●		43	1.250	1.000	6.000	1.188	1.250	1.250	IWSN432	NL46	CL20	XNS48
MWLN/L-204D	●	●		43	1.250	1.250	6.000	1.188	1.250	1.500	IWSN432	NL46	CL20	XNS48
MWLN/L-165D	●	●		54	1.000	1.000	6.000	1.188	1.000	1.250	IWSN533	NL34L	CL9	XNS59
MWLN/L-205D	●	●		54	1.250	1.250	6.000	1.125	1.250	1.500	IWSN533	NL34L	CL9	XNS59
MWLN/L-245E	●	●		54	1.500	1.500	7.000	1.125	1.500	2.000	IWSN533	NL58	CL9	XNS59

* Clamp Torque (lbf-in) : XNS36=30, XNS48=45, XNS59=70



DWLN type inserts > A128-A132
 MWLN type inserts > A128-A132
 CBN inserts > B032

CUTTING CONDITIONS > A074
 SPARE PARTS > M001
 TECHNICAL DATA > N001



EXTERNAL TURNING TOOLS

VB INSERTS TOOL HOLDERS

EXTERNAL TURNING TOOLS

Order Number		Stock		Insert Number		Dimensions (inch)					* 			
						H	B	LF	LH	HF	WF	Clamp Screw	Wrench	
SVJBR/L-062	●	●	VBGT VBMT VBET	22	.375	.375	2.500	.875	.375	.500	TS25	TKY08F		
SVJBR/L-082	●	●		22	.500	.500	3.500	.875	.500	.625	TS25	TKY08F		
SVJBR/L-102	●	●		22	.625	.625	4.000	.875	.625	.750	TS25	TKY08F		
SVJBR/L-123	●	●		33	.750	.750	4.500	1.250	.750	1.000	TS4	TKY15F		
SVJBR/L-163	●	●		33	1.000	1.000	6.000	1.250	1.000	1.250	TS4	TKY15F		

* Clamp Torque (lbf-in) : TS25=8.9, TS4=31

Order Number		Stock		Insert Number		Dimensions (inch)					* 			
						H	B	LF	HF	WF	Clamp Screw	Wrench		
SVVBN-062	●		VBGT VBMT VBET	22	.375	.375	2.500	.375	.188	TS25	TKY08F			
SVVBN-082	●			22	.500	.500	3.000	.500	.250	TS25	TKY08F			
SVVBN-102	●			22	.625	.625	4.000	.625	.313	TS25	TKY08F			
SVVBN-122	●			22	.750	.750	4.500	.750	.375	TS25	TKY08F			
SVVBN-123	●			33	.750	.750	4.500	.750	.375	TS4	TKY15F			
SVVBN-163	●		33	1.000	1.000	6.000	1.000	.500	TS4	TKY15F				

* Clamp Torque (lbf-in) : TS25=8.9, TS4=31

(Note) Insert photo is an example. Letters show chip breaker style, figures show inscribed circle.

SVHB

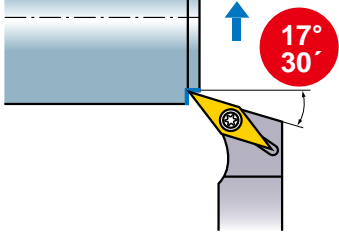



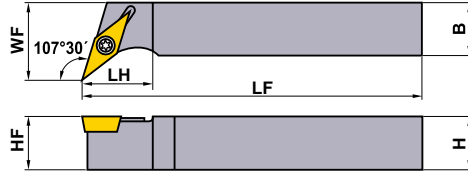

Facing

Screw Clamp Type
SP Holder



Right hand tool holder shown.

Finish	Finish
FV  (2)	FP  (3)
Medium	Medium
MV  (2)	MP  (3)

Order Number	Stock		Insert Number	Dimensions (inch)						* 		
	R	L		H	B	LF	LH	HF	WF	Clamp Screw	Wrench	
SVHBR/L-062	●	●	VBGT VBMT VBET	22	.375	.375	2.500	.600	.375	.500	TS25	TKY08F
SVHBR/L-082	●	●		22	.500	.500	3.500	.600	.500	.625	TS25	TKY08F
SVHBR/L-102	●	●		22	.625	.625	4.000	.600	.625	.750	TS25	TKY08F
SVHBR/L-123	●	●		33	.750	.750	4.500	1.000	.750	1.000	TS4	TKY15F
SVHBR/L-163	●	●		33	1.000	1.000	6.000	1.000	1.000	1.250	TS4	TKY15F

* Clamp Torque (lbf-in) : TS25=8.9, TS4=31

EXTERNAL TURNING TOOLS

SVHB type inserts > A162-A165
 CBN & PCD inserts > B044, B060
 CUTTING CONDITIONS > A074

SPARE PARTS > M001
 TECHNICAL DATA > N001

EXTERNAL TURNING TOOLS

CC INSERTS TOOL HOLDERS



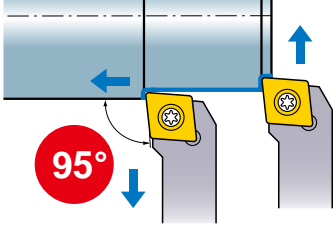



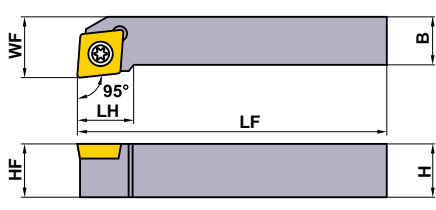

SCLC







External turning Facing **Screw Clamp Type SP Holder**



Right hand tool holder shown.

Finish	Finish	Light	Light
FP  (2,3)	FM  (2,3)	LP  (2,3)	LM  (2,3)
Medium MP  (2,3,4)	Medium MM  (2,3,4)	Flat Top  (2,3,4)	PCD/CBN  (2,3,4)

EXTERNAL TURNING TOOLS

Order Number	Stock		Insert Number	Dimensions (inch)									
	R	L		H	B	LF	LH	HF	WF	Shim	Shim Screw	Clamp Screw	Wrench
SCLCR/L-062	●	●	CCET 21.5	.375	.375	2.500	.350	.375	.500	—	—	TS25	①TKY08F
SCLCR/L-083	●	●	CCGT 32.5	.500	.500	3.500	.540	.500	.625	—	—	TS43	①TKY15F
SCLCR/L-104	●	●	CCMT 43	.625	.625	4.000	.660	.625	.750	—	—	TS5	①TKY25F
SCLCR/L-124	●	●	CCMW 43	.750	.750	4.500	.660	.750	.875	SPSCN42	JSS7	TS53	②TKY25R
SCLCR/L-164	●	●	CCGW CCMH 43	1.000	1.000	6.000	1.000	1.000	1.250	SPSCN42	JSS7	TS53	②TKY25R

* Clamp Torque (lbf-in) : TS25=8.9, TS43=31, TS5=66, TS53=66

(Note) Insert photo is an example. Letters show chip breaker style, figures show inscribed circle.

SCLC type inserts	> A136–A141
CBN & PCD inserts	> B036, B037, B055
CUTTING CONDITIONS	> A074

DC INSERTS TOOL HOLDERS

SDJC		External turning Copying		Screw Clamp Type SP Holder		Finish		Finish		Light		Light	
						FP	FM	LP	LM				
						 (2,3)		 (2,3)		 (2,3)		 (2,3)	
						Medium		Medium		Flat Top		PCD/CBN	
						 (2,3)		 (2,3)		 (2,3)		 (2,3)	
						MP		MM		Flat Top		PCD/CBN	

Right hand tool holder shown.

Order Number	Stock		Insert Number	Dimensions (inch)						Shim	Shim Screw	Clamp Screw *	Wrench	
	R	L		H	B	LF	LH	HF	WF					
SDJCR/L-062	●	●	DCET DCGT DCMT DCMW	21.5	.375	.375	2.500	.500	.375	.500	—	—	TS25	①TKY08F
SDJCR/L-083	●	●		32.5	.500	.500	3.500	.700	.500	.625	—	—	TS43	①TKY15F
SDJCR/L-103	●	●		32.5	.625	.625	4.000	.700	.625	.750	—	—	TS43	①TKY15F
SDJCR/L-123	●	●		32.5	.750	.750	4.500	.700	.750	.875	SPSDN32	JSS6	TS406	②TKY15R
SDJCR/L-163	●	●		32.5	1.000	1.000	6.000	1.000	1.000	1.250	SPSDN32	JSS6	TS406	②TKY15R

* Clamp Torque (lbf-in) : TS25=8.9, TS43=31, TS406=31

SDNC		External turning Copying		Screw Clamp Type SP Holder		Finish		Finish		Light		Light	
						FP	FM	LP	LM				
						 (2,3)		 (2,3)		 (2,3)		 (2,3)	
						Medium		Medium		Flat Top		PCD/CBN	
						 (2,3)		 (2,3)		 (2,3)		 (2,3)	
						MP		MM		Flat Top		PCD/CBN	

Order Number	Stock		Insert Number	Dimensions (inch)						Shim	Shim Screw	Clamp Screw *	Wrench
	R	L		H	B	LF	HF	WF					
SDNCN-062	●		DCET DCGT DCMT DCMW	21.5	.375	.375	2.500	.375	.188	—	—	TS25	①TKY08F
SDNCN-083	●			32.5	.500	.500	3.500	.500	.250	—	—	TS43	①TKY15F
SDNCN-103	●			32.5	.625	.625	4.000	.625	.313	—	—	TS43	①TKY15F
SDNCN-123	●			32.5	.750	.750	4.500	.750	.375	SPSDN32	JSS6	TS406	②TKY15R
SDNCN-163	●			32.5	1.000	1.000	6.000	1.000	.500	SPSDN32	JSS6	TS406	②TKY15R

* Clamp Torque (lbf-in) : TS25=8.9, TS43=31, TS406=31

EXTERNAL TURNING TOOLS

SDJC type inserts > A144-A149
 SDNC type inserts > A144-A149
 CBN & PCD inserts > B039, B040, B056



CUTTING CONDITIONS > A074
 SPARE PARTS > M001
 TECHNICAL DATA > N001

DC INSERTS TOOL HOLDERS

SDXC

External turning
Copying

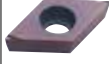

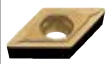
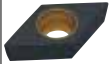
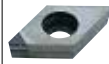
Screw Clamp Type
SP Holder

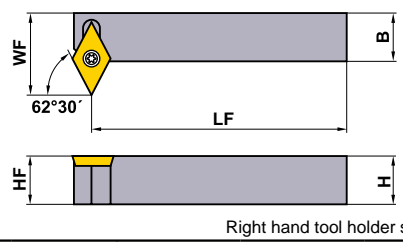
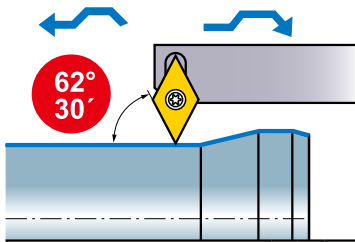
Finish	Finish	Light	Medium
FV	R/L-F	SV	MV
 (2,3)	 (2,3)	 (2,3)	 (2,3)
Medium	Flat Top	CBN/PCD	
Standard	 (2,3)	 (2,3)	 (2,3)



Right hand tool holder shown.

EXTERNAL TURNING TOOLS

Order Number	Stock		Insert Number	Dimensions (inch)					*  	
	R	L		H	B	LF	HF	WF	Clamp Screw	Wrench
SDXCR/L-062	●	●	DCET 21.5	.375	.375	2.500	.375	.625	TS25	TKY08F
SDXCR/L-082	●	●	DCGT 21.5	.500	.500	3.500	.500	.750	TS25	TKY08F
SDXCR/L-103	●	●	DCMT DCMW 32.5	.625	.625	4.000	.625	1.000	TS43	TKY15F

* Clamp Torque (lbf-in) : TS25=8.9, TS43=31

(Note) Insert photo is an example. Letters show chip breaker style, figures show inscribed circle.

SDXC type inserts > A144–A149
 CBN & PCD inserts > B039, B040, B056
 CUTTING CONDITIONS > A074

RC INSERTS TOOL HOLDERS

SRGC

External turning
Copying

Screw Clamp Type
SP Holder

Medium
Standard

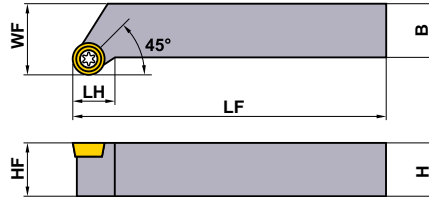
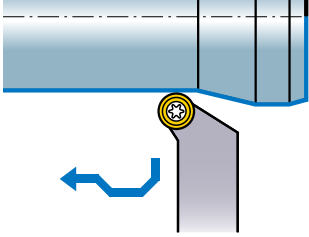

Right hand tool holder shown.

Order Number	Stock		Insert Number	Dimensions (inch)						* Clamp Screw	Wrench	
	R	L		H	B	LF	LH	HF	WF			
SRGCR/L-0608M	●	●	RCMT	0803M0	.375	.375	2.500	.610	.375	.625	TS3	TKY08F
SRGCR/L-0808M	●	●		0803M0	.500	.500	3.500	.610	.500	.750	TS3	TKY08F
SRGCR/L-1008M	●	●		0803M0	.625	.625	4.000	.610	.625	.875	TS3	TKY08F

* Clamp Torque (lbf-in) : TS3=8.9

SRDC

External turning
Copying

Screw Clamp Type
SP Holder

Medium
Standard

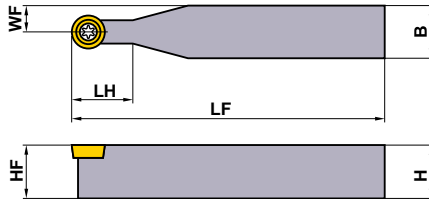
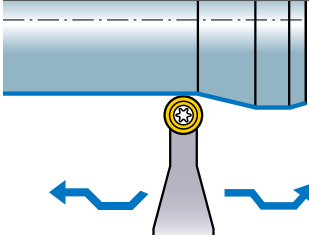

Order Number	Stock		Insert Number	Dimensions (inch)						* Clamp Screw	Wrench	
	R	L		H	B	LF	LH	HF	WF			
SRDCN-0608M	●		RCMT	0803M0	.375	.375	2.500	.375	.375	.188	TS3	TKY08F
SRDCN-0808M	●			0803M0	.500	.500	3.500	.500	.500	.250	TS3	TKY08F
SRDCN-1008M	●			0803M0	.625	.625	4.000	.500	.625	.313	TS3	TKY08F

* Clamp Torque (lbf-in) : TS3=8.9

SRGC type inserts > A151
 SRDC type inserts > A151
 CUTTING CONDITIONS > A074

SPARE PARTS > M001
 TECHNICAL DATA > N001

EXTERNAL TURNING TOOLS

EXTERNAL TURNING TOOLS

SC INSERTS TOOL HOLDERS

EXTERNAL TURNING TOOLS

Order Number		Stock		Insert Number	Dimensions (inch)					Shim		Shim Screw		Clamp Screw		Wrench	
		R	L		H	B	LF	HF	WF	Shim	Shim Screw	Clamp Screw	Wrench				
SSBCR/L-103	●	●	SCMT SCMW	32.5	.625	.625	4.000	.625	.500	—	—	TS43	⓪TKY15F				
SSBCR/L-124	●	●		43	.750	.750	4.500	.750	.625	SPSSN42	JSS7	TS53	⓪TKY25R				
SSBCR/L-164	●	●		43	1.000	1.000	6.000	1.000	.875	SPSSN42	JSS7	TS53	⓪TKY25R				

* Clamp Torque (lbf-in) : TS43=31, TS53=66

Order Number		Stock		Insert Number	Dimensions (inch)					Shim		Shim Screw		Clamp Screw		Wrench	
		R	L		H	B	LF	LH	HF	WF	Shim	Shim Screw	Clamp Screw	Wrench			
SSSCR/L-083	●	●	SCMT SCMW	32.5	.500	.500	3.500	.625	.500	.550	—	—	TS43	⓪TKY15F			
SSSCR/L-103	●	●		32.5	.625	.625	4.000	.625	.625	.680	—	—	TS43	⓪TKY15F			
SSSCR/L-124	●	●		43	.750	.750	4.500	1.000	.750	.850	SPSSN42	JSS7	TS53	⓪TKY25R			
SSSCR/L-164	●	●		43	1.000	1.000	6.000	1.000	1.000	1.110	SPSSN42	JSS7	TS53	⓪TKY25R			

* Clamp Torque (lbf-in) : TS43=31, TS53=66

(Note) Insert photo is an example. Letters show chip breaker style, figures show inscribed circle.

SSBC type inserts > A152, A153
 SSSC type inserts > A152, A153
 CUTTING CONDITIONS > A074

TC INSERTS TOOL HOLDERS

STGC		Screw Clamp Type SP Holder								Finish		Light	
		External turning								FP	FM	LP	LM
										(2,3)	(2,3)	(2,3)	(2,3)
		<i>Right hand tool holder shown.</i>								Medium	Medium	Flat Top	PCD/CBN
										MP	MM		
										(2,3)	(2,3)	(2,3)	(2,3)

Order Number	Stock		Insert Number	Dimensions (inch)										
	R	L		H	B	LF	LH	HF	WF	Shim	Shim Screw	Clamp Screw	Wrench	
STGCR/L-062	●	●	TCGT TCMT TCMW	21.5	.375	.375	2.500	.550	.375	.500	—	—	TS25	①TKY08F
STGCR/L-082.5	●	●		2.52	.500	.500	3.500	.700	.500	.625	—	—	TS3	①TKY08F
STGCR/L-103	●	●		32.5	.625	.625	4.000	.800	.625	.750	—	—	TS43	①TKY15F
STGCR/L-123	●	●		32.5	.750	.750	4.500	.800	.750	.875	SPSTN32	JSS6	TS406	②TKY15R
STGCR/L-163	●	●		32.5	1.000	1.000	6.000	.900	1.000	1.250	SPSTN32	JSS6	TS406	②TKY15R

* Clamp Torque (lbf-in) : TS25=8.9, TS3=8.9, TS43=31, TS406=31

STFC		Screw Clamp Type SP Holder								Finish		Light	
		Facing								FP	FM	LP	LM
										(2,3)	(2,3)	(2,3)	(2,3)
		<i>Right hand tool holder shown.</i>								Medium	Medium	Flat Top	PCD/CBN
										MP	MM		
										(2,3)	(2,3)	(2,3)	(2,3)

Order Number	Stock		Insert Number	Dimensions (inch)										
	R	L		H	B	LF	LH	HF	WF	Shim	Shim Screw	Clamp Screw	Wrench	
STFCR/L-062	●	●	TCGT TCMT TCMW	21.5	.375	.375	2.500	.500	.375	.500	—	—	TS25	①TKY08F
STFCR/L-082.5	●	●		2.52	.500	.500	3.500	.571	.500	.625	—	—	TS3	①TKY08F
STFCR/L-102.5	●	●		2.52	.625	.625	4.000	.571	.625	.750	—	—	TS3	①TKY08F
STFCR/L-123	●	●		32.5	.750	.750	4.500	.866	.750	.875	SPSTN32	JSS6	TS406	②TKY15R
STFCR/L-163	●	●		32.5	1.000	1.000	6.000	.866	1.000	1.250	SPSTN32	JSS6	TS406	②TKY15R

* Clamp Torque (lbf-in) : TS25=8.9, TS3=8.9, TS406=31

STGC type inserts > A155-A157
 STFC type inserts > A155-A157
 CBN & PCD inserts > B041, B057

CUTTING CONDITIONS > A074
 SPARE PARTS > M001
 TECHNICAL DATA > N001

EXTERNAL TURNING TOOLS

EXTERNAL TURNING TOOLS

VC INSERTS TOOL HOLDERS

EXTERNAL TURNING TOOLS

Order Number		Stock		Insert Number	Dimensions (inch)					Accessories				
		R	L		H	B	LF	LH	HF	WF	Shim	Shim Pin	Clamp Screw	Wrench
SVPCR/L-082	●●	●●	VCMT VCGT VCMW NP-VCGW	22	.500	.500	3.500	1.000	.500	.750	—	—	TS25	①TKY08F
SVPCR/L-102	●●	●●		22	.625	.625	4.000	1.000	.625	.875	—	—	TS25	①TKY08F
SVPCR/L-123	●●	●●		33	.750	.750	4.500	1.206	.750	1.000	SPSVN32	BCP141	TS44	②TKY15R
SVPCR/L-163	●●	●●		33	1.000	1.000	6.000	1.206	1.000	1.250	SPSVN32	BCP141	TS44	②TKY15R

* Clamp Torque (lbf-in) : TS25=8.9, TS44=31

Order Number		Stock		Insert Number	Dimensions (inch)					Accessories				
		R	L		H	B	LF	LH	HF	WF	Shim	Shim Pin	Clamp Screw	Wrench
SVJCR/L-062	●●	●●	VCMT VCGT VCMW NP-VCGW	22	.375	.375	2.500	.750	.375	.500	—	—	TS25	①TKY08F
SVJCR/L-083	●●	●●		33	.500	.500	3.500	1.000	.500	.625	—	—	TS43	①TKY15F
SVJCR/L-103	●●	●●		33	.625	.625	4.000	1.000	.625	.750	—	—	TS43	①TKY15F
SVJCR/L-123	●●	●●		33	.750	.750	4.500	1.000	.750	.875	SPSVN32	BCP141	TS44	②TKY15R
SVJCR/L-163	●●	●●		33	1.000	1.000	6.000	1.500	1.000	1.250	SPSVN32	BCP141	TS44	②TKY15R

* Clamp Torque (lbf-in) : TS25=8.9, TS43=31, TS44=31

(Note) Insert photo is an example. Letters show chip breaker style, figures show inscribed circle.

SVPC type inserts	➤ A166, A167
SVJC type inserts	➤ A166, A167
CBN & PCD inserts	➤ B045, B060
CUTTING CONDITIONS	➤ A074

WC INSERTS TOOL HOLDERS

SWLC

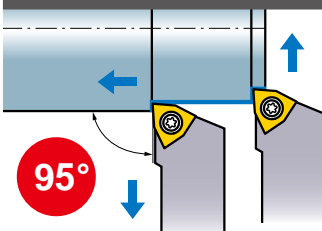



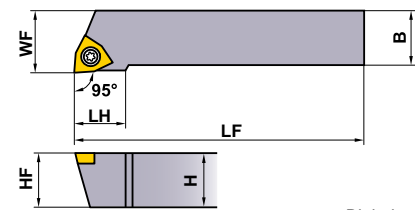

External turning Facing



**Screw Clamp Type
SP Holder**

Right hand tool holder shown.

Finish	Medium
FJ  (2,3)	MJ  (2,3)
Medium Standard  (2,3)	

Order Number	Stock		Insert Number	Dimensions (inch)						 *		
	R	L		H	B	LF	LH	HF	WF	Clamp Screw	Wrench	
SWLCR/L-052	●	●	WCGT WCMT	21.5 [○]	.313	.313	2.500	.500	.313	.375	TS25	TKY08F
SWLCR/L-062	●	●		21.5 [○]	.375	.375	2.500	.500	.375	.500	TS25	TKY08F
SWLCR/L-082	●	●		21.5 [○]	.500	.500	3.500	.500	.500	.625	TS25	TKY08F
SWLCR/L-103	●	●		32.5 [○]	.625	.625	4.000	.625	.625	.750	TS4	TKY15F
SWLCR/L-123	●	●		32.5 [○]	.750	.750	4.500	.625	.750	1.000	TS4	TKY15F

* Clamp Torque (lbf-in) : TS25=8.9, TS4=31

EXTERNAL TURNING TOOLS

SWLC type inserts	> A171	SPARE PARTS	> M001
CBN inserts	> B046	TECHNICAL DATA	> N001
CUTTING CONDITIONS	> A074		

XC^o INSERTS TOOL HOLDERS

EXTERNAL TURNING TOOLS



External turning Copying

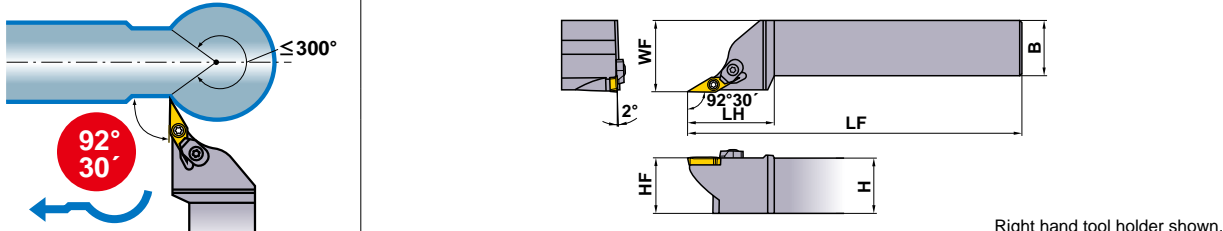

Right hand tool holder shown.

DOUBLE CLAMP Type

Finish SVX

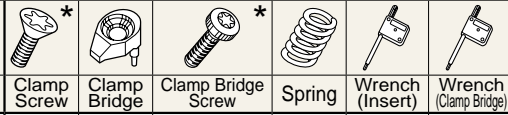

(2)

Order Number	Stock		Insert Number	Dimensions (inch)												
	R	L		H	B	LF	LH	HF	WF	Clamp Screw	Clamp Bridge	Clamp Bridge Screw	Spring	Wrench (Insert)	Wrench (Clamp Bridge)	
SXZCR/L-102	●	●	XCMT	22 ^o SVX	.625	.625	4.000	1.378	.625	.750	TS255	AMS3	AJS3010T10	ASS2	TKY08F	TKY10F
SXZCR/L-122	●	●		22 ^o SVX	.750	.750	4.500	1.378	.750	1.000	TS255	AMS3	AJS3010T10	ASS2	TKY08F	TKY10F
SXZCR/L-162	●	●		22 ^o SVX	1.000	1.000	6.000	1.575	1.000	1.250	TS255	AMS3	AJS3010T10	ASS2	TKY08F	TKY10F

* Clamp Torque (lbf-in) : TS255=8.9, AJS3010T10=22



External turning Copying

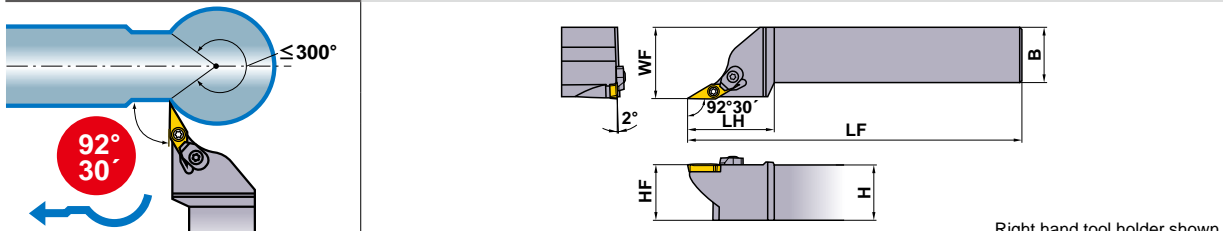

Right hand tool holder shown.

DOUBLE CLAMP Type

Finish SVX

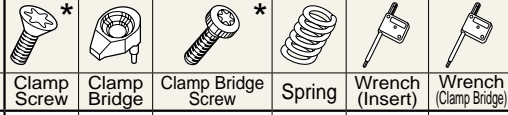

(2)

Order Number	Stock		Insert Number	Dimensions (mm)												
	R	L		H	B	LF	LH	HF	WF	Clamp Screw	Clamp Bridge	Clamp Bridge Screw	Spring	Wrench (Insert)	Wrench (Clamp Bridge)	
SXZCR/L1616H15	●	●	XCMT	22 ^o SVX	16	16	100	35	16	20	TS255	AMS3	AJS3010T10	ASS2	TKY08F	TKY10F
SXZCR/L2020K15	●	●		22 ^o SVX	20	20	125	35	20	25	TS255	AMS3	AJS3010T10	ASS2	TKY08F	TKY10F
SXZCR/L2525M15	●	●		22 ^o SVX	25	25	150	40	25	32	TS255	AMS3	AJS3010T10	ASS2	TKY08F	TKY10F

* Clamp Torque (lbf-in) : TS255=8.9, AJS3010T10=22

APPLICATION RANGE

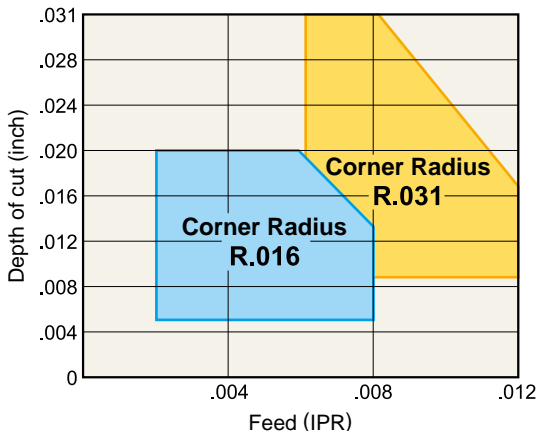

(Note) Insert photo is an example. Letters show chip breaker style, figures show inscribed circle.

RECOMMENDED CUTTING CONDITIONS

Work Material	Hardness	Grade	Cutting Speed (SFM)
P Mild Steel	≤ 180HB	UE6020	490—1150
General Steel	150HB—250HB	UE6020	330—820

(Note) The above cutting conditions are general guide lines. Adjustments maybe necessary depending on machine rigidity, workpiece geometry and clamping.

OPERATIONAL GUIDANCE

Notes when end face profiling

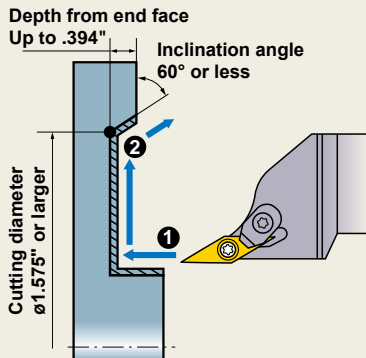

Pay special attention to the following when face profiling.

Machining of an outer diameter (Step ①)

- To prevent burr formation, the depth of cut should be less than half the corner radius.

Machining of an inclination (Step ②)

- To reduce the contact length of chips, the depth of cut should be less than half the corner radius.
- To prevent interference between the tool and the workpiece, the cutting diameter should be 1.575" or larger, inclination angle 60° or less and depth from the end face up to .394".

When changing inserts

- When indexing the inserts, it is recommended to preset the cutting edge position to maintain machining accuracy.

Not possible

Machining of V-pulleys

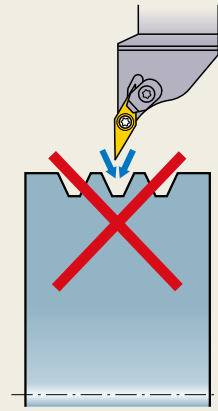

When machining V-pulleys, use a VNMG insert

EXTERNAL TURNING TOOLS

RP INSERTS TOOL HOLDERS

EXTERNAL TURNING TOOLS

SRDPR/L

External turning
Copying

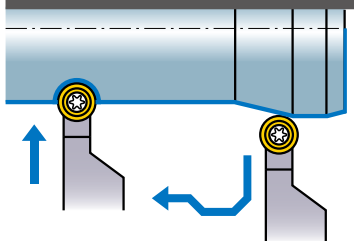

Screw Clamp Type
SP Holder

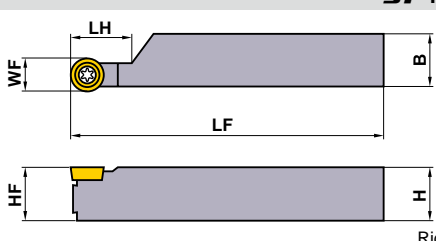



Right hand tool holder shown.

Medium
JS



(12)

Order Number	Stock		Insert Number	Dimensions (inch)						*  	
	R	L		WF	H	B	LF	LH	HF	Clamp Screw	Wrench
SRDPR/L-1612	●	●	RPMT120400E-JS	.500	1.000	1.000	6.000	1.000	1.000	TS43	TKY15F

* Clamp Torque (lbf-in) : TS43=31

SRDPN

External turning
Copying

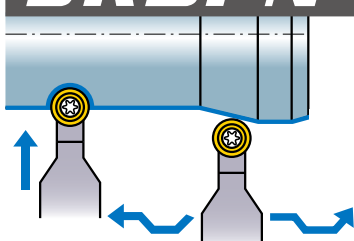

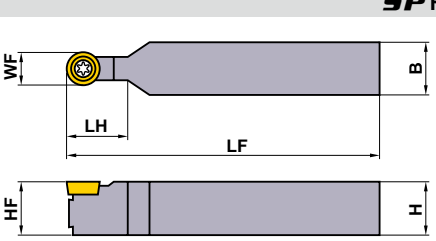

Screw Clamp Type
SP Holder



Medium
JS



(12)

Order Number	Stock		Insert Number	Dimensions (inch)						*  	
	R	L		WF	H	B	LF	LH	HF	Clamp Screw	Wrench
SRDPN-1612	●		RPMT120400E-JS	.500	1.000	1.000	6.000	1.000	1.000	TS43	TKY15F

* Clamp Torque (lbf-in) : TS43=31

(Note) Insert photo is an example. Letters show chip breaker style, figures show inscribed circle.

SRDPR/L type inserts > J022
 SRDPN type inserts > J022
 CUTTING CONDITIONS > A074

DE INSERTS TOOL HOLDERS

SDJE

External turning
Copying

Screw Clamp Type for Aluminum
AL Holder

Medium
R/L

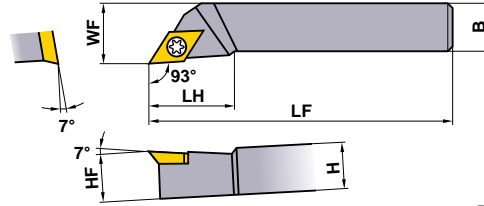
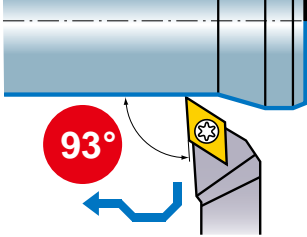

Right hand tool holder shown.







(4)

PCD

R/L-F



(4)

Order Number	Stock		Insert Number	Dimensions (inch)						 * Clamp Screw	 Wrench	
	R	L		H	B	LF	LH	HF	WF			
SDJER/L-104	●	●	DEGX	43 	.625	.625	4.000	1.000	.625	.750	CS451190T	TKY20F
SDJER/L-124	●	●		43 	.750	.750	4.500	1.000	.750	.875	CS451190T	TKY20F
SDJER/L-164	●	●		43 	1.000	1.000	6.000	1.100	1.000	1.250	CS451190T	TKY20F

* Clamp Torque (lbf-in) : CS451190T=44

EXTERNAL TURNING TOOLS

RECOMMENDED CUTTING CONDITIONS

Work Material	Grade	Cutting Speed (SFM)	Feed (IPR)	Depth of Cut (inch)
N Aluminum Alloy	HTi10	1310	.002-.012	.008-.118

SDJE type inserts > A150
PCD inserts > B062

SPARE PARTS > M001
TECHNICAL DATA > N001

TE INSERTS TOOL HOLDERS

EXTERNAL TURNING TOOLS

STGE

External turning

Screw Clamp Type for Aluminum AL Holder

Right hand tool holder shown.

Medium

R/L

(3)

PCD

R/L

(3)

Order Number	Stock		Insert Number	Dimensions (inch)						*		
	R	L		H	B	LF	LH	HF	WF			Clamp Screw
STGER/L-103	●	●	TEGX	32○R/L	.625	.625	4.000	.800	.625	.750	FC400890T	TKY10F
STGER/L-123	●	●		32○R/L	.750	.750	4.500	.800	.750	.875	FC400890T	TKY10F
STGER/L-163	●	●		32○R/L	1.000	1.000	6.000	.900	1.000	1.250	FC400890T	TKY10F

(Note) Right hand toolholder uses right hand insert. Left hand toolholder uses left hand insert.
 * Clamp Torque (lbf-in) : FC400890T=22

STFE

Facing

Screw Clamp Type for Aluminum AL Holder

Right hand tool holder shown.

Medium

R/L

(3)

PCD

R/L

(3)





Order Number	Stock		Insert Number	Dimensions (inch)						*		
	R	L		H	B	LF	LH	HF	WF			Clamp Screw
STFER/L-103	●	●	TEGX	32○R/L	.625	.625	4.000	.866	.625	.750	FC400890T	TKY10F
STFER/L-123	●	●		32○R/L	.750	.750	4.500	.866	.750	1.000	FC400890T	TKY10F
STFER/L-163	●	●		32○R/L	1.000	1.000	6.000	.866	1.000	1.250	FC400890T	TKY10F

(Note) Right hand toolholder uses left hand insert. Left hand toolholder uses right hand insert.
 * Clamp Torque (lbf-in) : FC400890T=22

(Note) Insert photo is an example. Letters show chip breaker style, figures show inscribed circle.

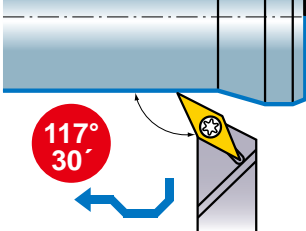
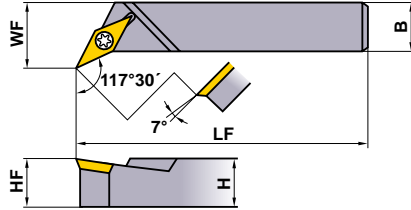



- STGE type inserts > A158
- STFE type inserts > A158
- PCD inserts > B062

VD INSERTS TOOL HOLDERS

SVPD		External turning Copying		Screw Clamp Type for Aluminum AL Holder						Finish	
										R/L	
				Right hand tool holder shown.						(3)	
Order Number	Stock		Insert Number	Dimensions (inch)							
	R	L		H	B	LF	HF	WF	Clamp Screw		
SVPDR/L-123	●	●	VDGX	32 \circ R/L	.750	.750	4.500	.750	1.000	FC400890T	TKY10F
SVPDR/L-163	●	●		32 \circ R/L	1.000	1.000	6.000	1.000	1.250	FC400890T	TKY10F

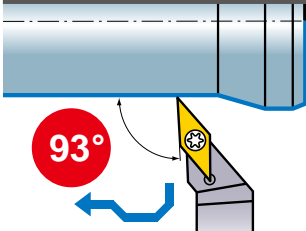
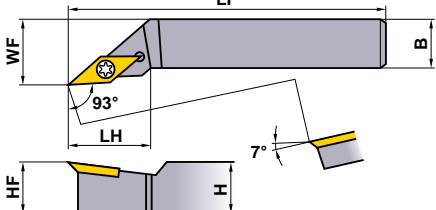
(Note) Right hand toolholder uses right hand insert. Left hand toolholder uses left hand insert.

* Clamp Torque (lbf-in) : FC400890T=22

SVJD		External turning Copying		Screw Clamp Type for Aluminum AL Holder						Finish		
										R/L		
				Right hand tool holder shown.						(3)		
Order Number	Stock		Insert Number	Dimensions (inch)								
	R	L		H	B	LF	LH	HF	WF			Clamp Screw
SVJDR/L-103	●	●	VDGX	32 \circ R/L	.625	.625	4.000	1.100	.625	.750	FC400890T	TKY10F
SVJDR/L-123	●	●		32 \circ R/L	.750	.750	4.500	1.100	.750	.875	FC400890T	TKY10F
SVJDR/L-163	●	●		32 \circ R/L	1.000	1.000	6.000	1.200	1.000	1.250	FC400890T	TKY10F

(Note) Right hand toolholder uses right hand insert. Left hand toolholder uses left hand insert.

* Clamp Torque (lbf-in) : FC400890T=22

EXTERNAL TURNING TOOLS

RECOMMENDED CUTTING CONDITIONS

Work Material	Grade	Cutting Speed (SFM)	Feed (IPR)	Depth of Cut (inch)
N Aluminum Alloy	HTi10	1310	.002— .012	.008— .118

SVPD type inserts > A168
SVJD type inserts > A168
PCD inserts > B063

SPARE PARTS > M001
TECHNICAL DATA > N001

RG INSERTS TOOL HOLDERS

EXTERNAL TURNING TOOLS

SRSGR/L

External turning Copying

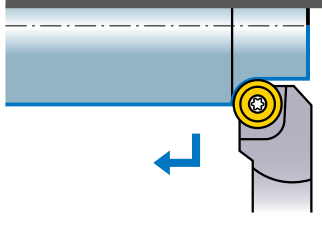

Screw Clamp Type
SR Holder

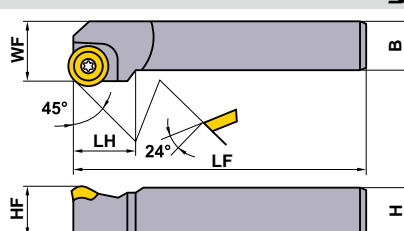



Right hand tool holder shown.

Medium Standard



(20)

Order Number	Stock		Insert Number	Dimensions (inch)						*  	
	R	L		H	B	LF	LH	HF	WF	Clamp Screw	Wrench
SRSGR/L-1620M	●	●	RGGM2004M0	1.000	1.000	6.000	1.181	1.000	1.250	TS5	TKY25F
SRSGR/L-8520M	●	●		1.250	1.000	7.000	1.181	1.250	1.250	TS5	TKY25F

* Clamp Torque (lbf-in) : TS5=66

SRSGN

External turning

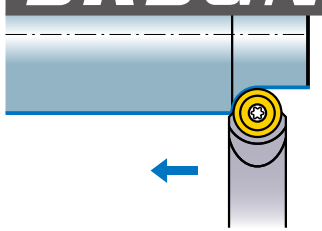

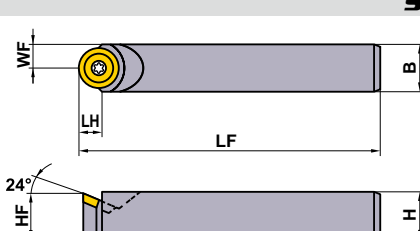

Screw Clamp Type
SR Holder



Medium Standard



(20)

Order Number	Stock		Insert Number	Dimensions (inch)						*  	
	R	L		H	B	LF	LH	HF	WF	Clamp Screw	Wrench
SRSGN-1620M	●	●	RGGM2004M0	1.000	1.000	6.000	.310	1.000	.500	TS5	TKY25F
SRSGN-8520M	●	●		1.250	1.000	7.000	.310	1.250	.500	TS5	TKY25F

* Clamp Torque (lbf-in) : TS5=66

